

CHAPTER 9 REVISION LIST



The following list of revisions will allow you to update the Lancair ES construction manual chapter listed above.

Under the "Action" column, "R&R" directs you to remove and replace the pages affect by the revision. "Add" directs you to insert the pages shown and "R" to remove the pages.

Page(s) affected	Current Rev.#	Action	Description
9-1 thru 9-8	0	None	Modified figure and text
9-9	6	R&R	
9-10 thru 9-58	0	None	



9-i

Chapter	6/4-1-99
OUTBOARD WING SECTIONS	

CHAPTER 9: OUTBOARD WING SECTIONS

REVISIONS

From time to time, revisions to this assembly manual may be deemed necessary. When such revisions are made, you should immediately replace all outdated pages with the revised pages. Discard the out dated pages. Note that on the lower right corner of each page is a "revision date". Initial printings will have the number "0" printed and the printing date. All subsequent revisions will have the revision number followed by the date of that revision. When such revisions are made, a "table of revisions" page will also be issued. This page (or pages) should be inserted in front of the opening page (this page) of each affected chapter. A new "table of revisions" page will accompany any revision made to a chapter.

Arrows

Most drawings will have arrows to show which direction the parts are facing, unless the drawing itself makes that very obvious. "A/C UP" refers to the direction that would be up if the part were installed in a plane sitting in the upright position. In most cases the part shown will be oriented in the same position as the part itself will be placed during that particular assembly step. However, time goes on and changes are made, so careful attention should be paid to the orientation arrows. That old cartoon of the guy agonizing over the plans for his canoe, built one end up, one end down, should not happen in real life. Especially to you.

CONTENTS

1. INTRODUCTION
2. DRAWING LIST
3. SPECIAL PARTS, TOOLS & SUPPLIES LIST
 - A. PARTS
 - B. TOOLS
 - C. MATERIALS & SUPPLIES
4. PROCEDURE
 - A. ATTACHING OUTBOARD WINGS TO FSLG
 - B. BL 105.5 RIB MODIFICATION
 - C. AILERON BELLCRANK ASSEMBLY
 - D. BL 50 RIB MODIFICATION
 - E. FUEL PICKUP LINE
 - F. FUEL TANK PICK UP LINE SCREEN FILTER
 - G. VENT LINE INSTALLATION
 - H. FUEL TANK BAFFLES
 - I. FUEL FILLER CAP INSTALLATION
 - J. AFT SPAR ATTACH BOLT COVERING
 - K. LOWER OUTBD WING SKIN INSTALLATION
 - L. WING TIE DOWN POINTS (OPTIONAL PIECES)
 - M. FUEL TANK SUMP DRAIN INSTALLATION
 - N. AILERON INSPECTION PANEL
 - O. FUEL TANK SEALER INSTALLATION
 - P. FINAL CLOSEOUT OF LOWER WING SKIN ASSEMBLY
 - Q. FLAP HINGE POSITIONS ON LOWER OUTBD WING SKIN
 - R. WING TIP INSTALLATION
 - S. WING TIP LIGHTING
 - T. TAIL LIGHT INSTALLATION
 - U. WIRING THE LIGHTING SYSTEM

LANCAIR® 320FB

9-1

Chapter 9

REV.

0 / 11-1-91

OUTBOARD WING SECTIONS

1. INTRODUCTION

This section will describe the final assembly of the Lancair wings. It will require the fslg to be securely positioned inverted and levelled both fwd and aft and left and right. If you have room, set up to build both outbd wing sections at the same time. This is not necessary, but will save time.

One important aspect to remember when completing your wings: it is obviously important to build them as accurately as possible, but to an even greater extent, it is most important to build the left one exactly like the right one (or vice-versa).



2. DRAWING LIST

Drawing	Page	Title
9-1	9-8	Leveling Wing & Fuselage
9-2	9-9	Outbd Wing
9-3	9-10	Tip Rib Placement
9-4	9-12	Outbd Aft Spar Attachment
9-5	9-13	Aileron Hinge Mounting
9-6	9-14	Outbd Aft Spar Hard Point
9-7	9-15	Typical Control Hinge Installation
9-8	9-17	Aileron Bellcrank Assembly
9-9	9-19	Aileron Bellcrank Attach Bracket
9-10	9-21	Aileron Bellcrank Installation
9-11	9-22	Aileron Bellcrank Assembly
9-12	9-23	Slotting the BL-74 Rib
9-13	9-28	Fuel Tank Pickup Line Installation
9-14	9-29	Vent Line Installation
9-15	9-31	Wing Fuel Tank
9-16	9-33	Fuel Filler Cap Installation
9-17	9-34	Fuel Tank / Aft Spar Bolt Cover
9-18	9-36	Trimming Ribs
9-19	9-38	Rib Caps
9-20	9-40	Wing Tie Down Installation
9-21	9-42	Fuel Tank Sump Drain Installation
9-22	9-43	Aileron Bellcrank Inspection Access Panel
9-23	9-48	Flap hinge installation
9-24	9-49	Wing tip installation
9-25	9-51	Type 2- wing tip lighting
9-26	9-53	Wing tip lens
9-27	9-54	Wing tip position lights
9-28	9-55	Wing tip strobe light
9-29	9-56	Wing tip light installation
9-30	9-57	Tail light installation



3. EQUIPMENT REQUIRED - SPECIAL PARTS, TOOLS & SUPPLIES

A. Parts

Fuselage as completed to this point

Left wing skin and spar assembly

Right wing skin and spar assembly



B. Tools

- water level
- assorted wrenches
- metal shears (for trimming fiberglass - can use Dremel cutter or??)
- tape measure
- Dremel™ type rotary grinder
- drill motor
- drill bits:
 - 1/4"
 - #12
- vise with padded jaw
- 8' or 10' straight edge
- flaring tool
- hole saw, 2-1/2" diameter
- C-clamps (about 8)



C. Materials & supplies

- epoxy
- flox
- BID cloth
- micro
- 1/4" foam
- 1/2" foam
- 1" thick high density foam
- structural adhesive
- pop rivets (approx. 40)



4. PROCEDURE

A. Outboard wing sections

This section will describe the final assembly of the Lancair wings. It will require the fslg to be securely positioned inverted and levelled both fwd and aft and left and right. If you have room, set up to build both outbd wing sections at the same time. This is not necessary, but will save you time and help make them more alike.

One important aspect to remember when completing your wings: it is obviously important to build them as accurately as possible, but to an even greater extent, it is most important to build the left one exactly like the right one (or vice-versa).

1. Secure the fslg on a bench in the inverted position, similar to that performed for the belly pan installation. You can use the BL 50 reference lines to level everything fore-aft & left-right.
2. Attach the outbd wings.
3. With a water level, check the level condition, measured at each wing tip L.E., and from wing tip to wing tip. If there's a difference, shim the fslg (at the longerons) to make the tips level with each other. At this point in the assembly, you're most concerned with the wings matching up and if the fslg is a shim thickness off, that's OK. What is now more important is setting up to establish identical outbd wing washout and that requires the above level condition be established regarding wing dihedral, as measured on the tip L.E.
4. Construct the wing tip rib fixture per blueprint "E" and figure 9-1. Make two of them if you are going to be working on both wings at the same time. The purpose of this fixture is to support and maintain the wing in the proper position while you perform the next few weeks of work, so build it accordingly. The wing tip rib pattern is drawn to exterior dimension, so you can use it to trace the pattern onto the fixture.
5. Place the fixture in position under the wing(s), and adjust it so that it is supporting the wing, and everything is still level.
6. Secure the fixture to the floor, using Bondo or similar, so that it will not slide or move if bumped over the next several days of work.
7. The outboard upper wing skins may have to be trimmed down to align at BL 50. This will require a back and forth fit and trim. To allow for flexing, a 3/32" gap must be maintained all around the BL 50 butt line. Take care to establish this as a smooth, straight butt line with that 3/32" gap.

8. Make sure everything is still level, and that the top skins are meeting properly. When you are satisfied that all is correct, hold the aft spar plate in place (see fig. 9-4) and note that it will require a very slight bend to align properly with the inbd and outbd sections.

LEVELING WING & FUSELAGE

Figure 9-1

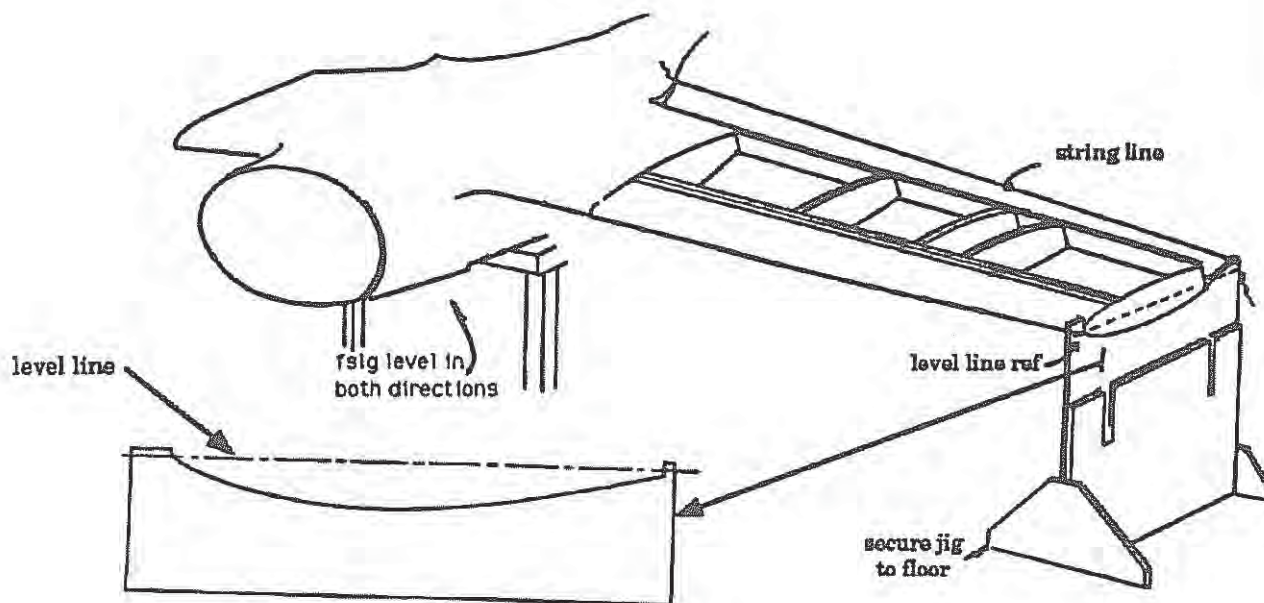

9. Using a vise with the jaws padded so that you won't gouge or scratch the surface, bend the spar bar slightly to match the angle of the aft spars. If you get any scratches or gouges, file them smooth and finish with 220-320 grit sandpaper.
10. Drill and attach the aft spar attach plate to the inbd section by drilling two 1/4" holes through it. Be sure to check for clearance from gear strut. Be sure that your bolts locate fully in the aluminum block that is in the ctr aft spar. This block is 5" long, see figure 9-4.

OUTBOARD WING

FIGURE 9-2

VIEWED FROM BOTTOM, SHOWING UPPER WING SKIN IN POSITION WITH UPPER WING SKIN AILERON AND FLAP DIMENSIONS

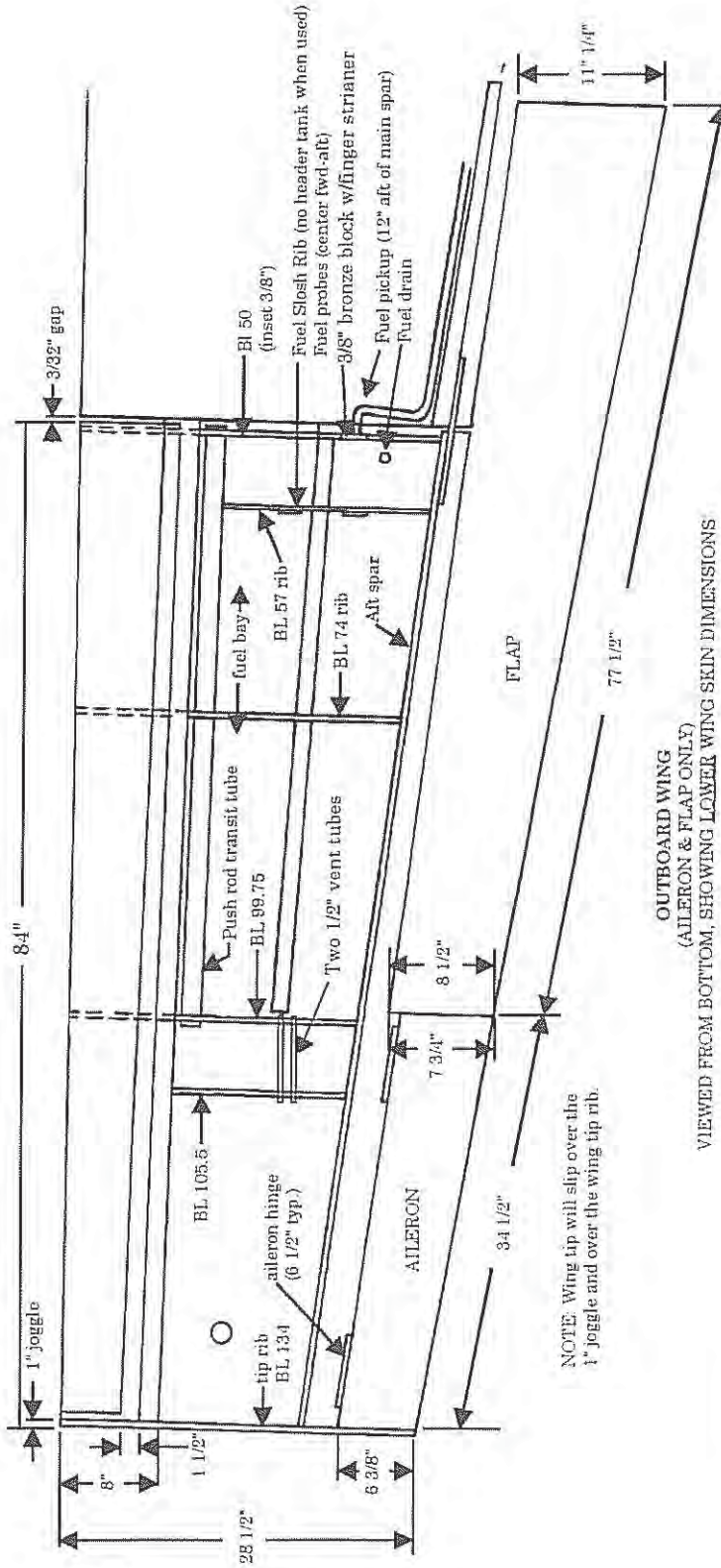

NOTE: Wing tip will slip over the 1" joggle and over the wing tip rib.

OUTBOARD WING (AILERON & FLAP ONLY) VIEWED FROM BOTTOM, SHOWING LOWER WING SKIN DIMENSIONS

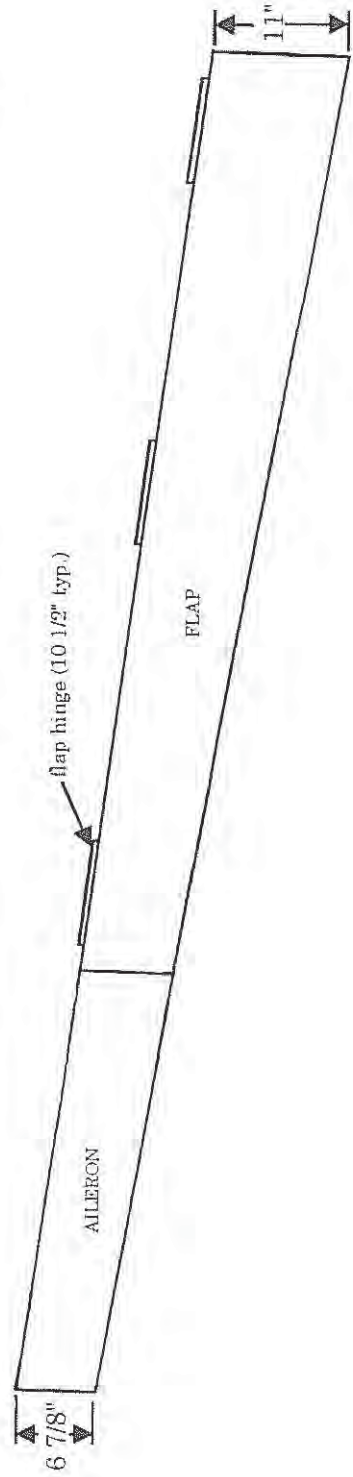

WING DIMENSION ALLOWABLES:

Wingspan: $\pm 1"$

Span variations from left to right are actually quite forgiving, but, excess variation could produce a rolling moment. A dimension measured from center line to the wing tip (at the main spar location) is very easy to establish to within $\pm 3/8"$ or so. When measuring along the trailing edge of the wing, dimensional variations can swing a little wider due to wing tip rib angle. This is more tolerable of variation.

Measure from the outbd edge of the aileron to the inbd edge of the flap. This dimension should be $\pm 1"$. Any variations can be split dimensionally between the aileron and flap however the aileron should not be made less than $34-1/2"$ long as shown in figure 9-2.

Setting wing tip / aileron butline position

See figure 9-3. Adjustment is very easy since the tip rib can essentially "float" inbd or outbd under the wing skins and thus it's location does not have to define the outbd edge of the aileron. The angle of the tip rib to the main spar is not critical thus the trailing edge of the tip rib may be inbd or outbd without adversely affecting the wing layout.

The outbd edge of the aileron is shown in figure 9-2 as being against the tip rib, **THIS IS NOT REQUIRED**. The tip rib may actually be outbd of the aileron edge and thus the wing tip panels (upper and lower) would simply extend over the rib to define the edge of the aileron. This could actually have a positive effect by providing an accessible joint surface onto which a 1 BID tape could be applied.

You will also note that the tip rib is generally positioned at a slight angle beyond "square" to the main spar, (off perpendicular by $3-4^\circ$'s), this is normal.

Tip rib placement

Figure 9-3

Example: If the wing tip rib were to be skewed outward at the trailing edge, the fit could still be easily made since the wing tips establish the aileron edge

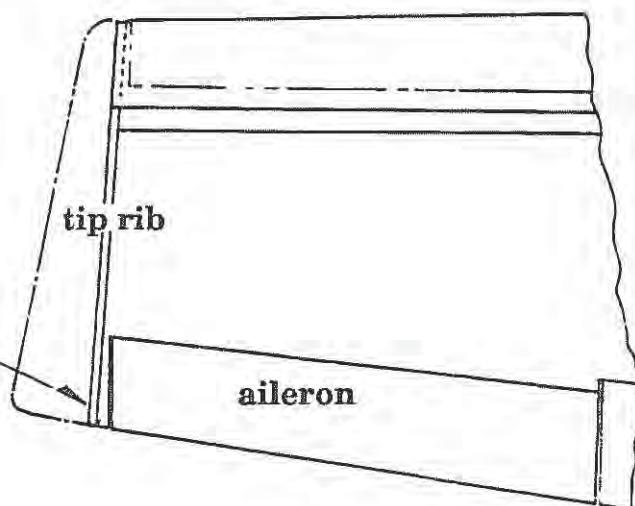

Additional wing tolerances:

See figure 9-2:

- Wing tip chord: $\pm 1/4"$.
- Total dimension of aileron and flaps along T.E. 112" - 113".
- Aileron span: 34.5" minimum
- Aileron chord: +0", -5/16" (the +0" is because adequate clearances must be provided for aileron counterbalance weights and flap rolled L.E.'s.)
- Rib BL stations: BL 74 rib: $\pm 1"$
BL 99.5 rib: +1/2", -1" (+ equates to farther outbd)
BL 105.5 rib: +1", -0".



11. Mark out and drill for the two outbd 1/4" attach bolts. Note that these bolts must be far enough outbd to clear the rib near BL 50 and give you enough room for the bolt head (or nut) and still be placed inside the area of the phenolic hard point (refer to figure 9-4).

The preferred method is with the bolt placed such that they enter from the aft with nuts fwd. Thus, if ever necessary, you'll be able to remove them without puncturing the fuel tank. See figure 9-17 for nut cover plate recommendation in fuel tank area.

OUTBD AFT SPAR ATTACHMENT
FIGURE 9-4

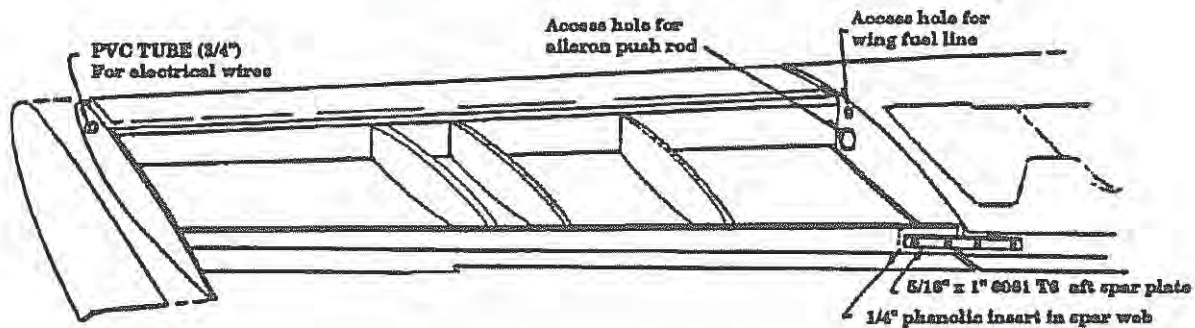

OUTBD AFT SPAR ATTACHMENT
MID-WEB, CUT-THROUGH VIEW, LOOKING DOWN ON LEFT WING

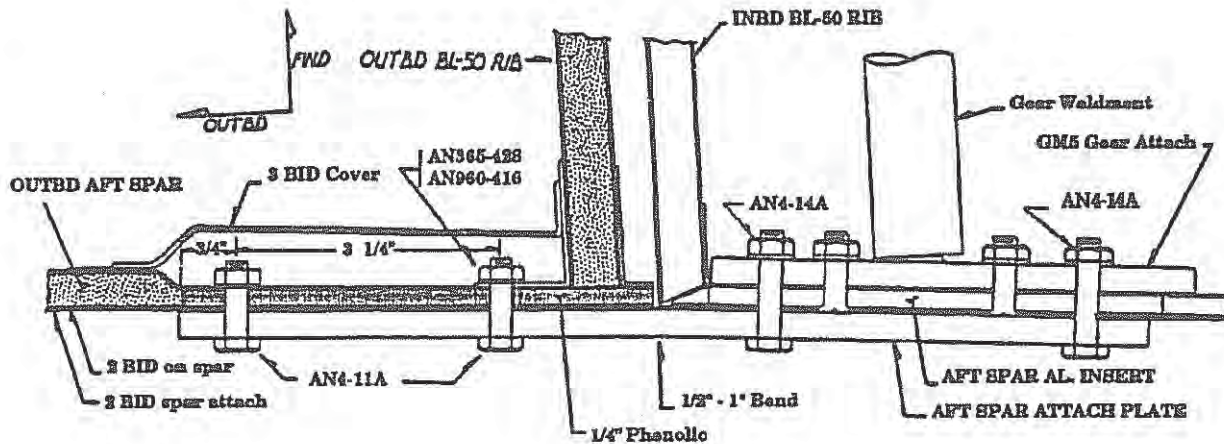

12. Per figure 9-2, mark out the trim lines on the upper wing skin for the aileron and flap. The line for the aileron will be a hinge line, the line for the flap will not since the flap hinges from the bottom skin. The flap line can be adjusted as the flap is installed. The aileron hinge line should be set accurately at this time.

There are already 2 BID applied to the full span between aft spar web and upper skin.

Note: Before starting this layup, have a straight edge handy long enough to go from the fslg to the wing tip.

13. At the locations of the two aileron hinge sections, six (6) additional BID must be applied (making a total layup of 8 BID at these locations - 2 are already done for you). These additional 6 BID must also run from skin T.E. fwd and lap onto the spar web to at least 50% of the web height (see figure 9-5). At these aileron hinge locations, the skin must be notched to nest the hinge pin sections and generate a narrow gap between aileron and wing skin, see figure 9-7. This notch should be done after all BID have been applied and have fully cured. With the trim line marked (using the string at wing T.E. as a measuring reference), trim and add the 6 BID at the aileron positions.
14. Place plastic over the wet BID (it is also a tidy idea to use peel-ply over the wet BID before adding the plastic). Now clamp the skin T.E.'s all the way from fslg to tip. You will be clamping onto the wet BID (that's why the plastic is used). This should give you a nice straight surface later for your hinges, and look good, too. Use care not to rub or shift the wet BID when clamping on the straight edges. Allow to cure.

AILERON HINGE MOUNTING

Figure 9-5

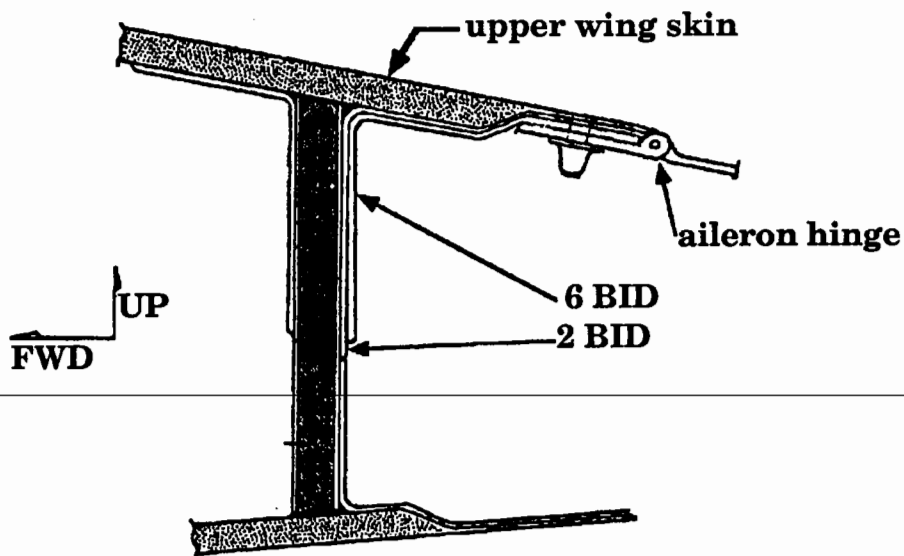

15. After cure, remove the clamps, plastic and peel-ply. Trim the layup bid to the previous trim lines. Use a heat gun to facilitate the trimming.
16. Cut the notches for the aileron hinges. See figure 9-7 for the best notch to fit the hinge sections. If this is done carefully, a very small gap between aileron and skin will result which is not only aerodynamically good but also looks good.

OUTBOARD AFT SPAR HARD POINT

Figure 9-6

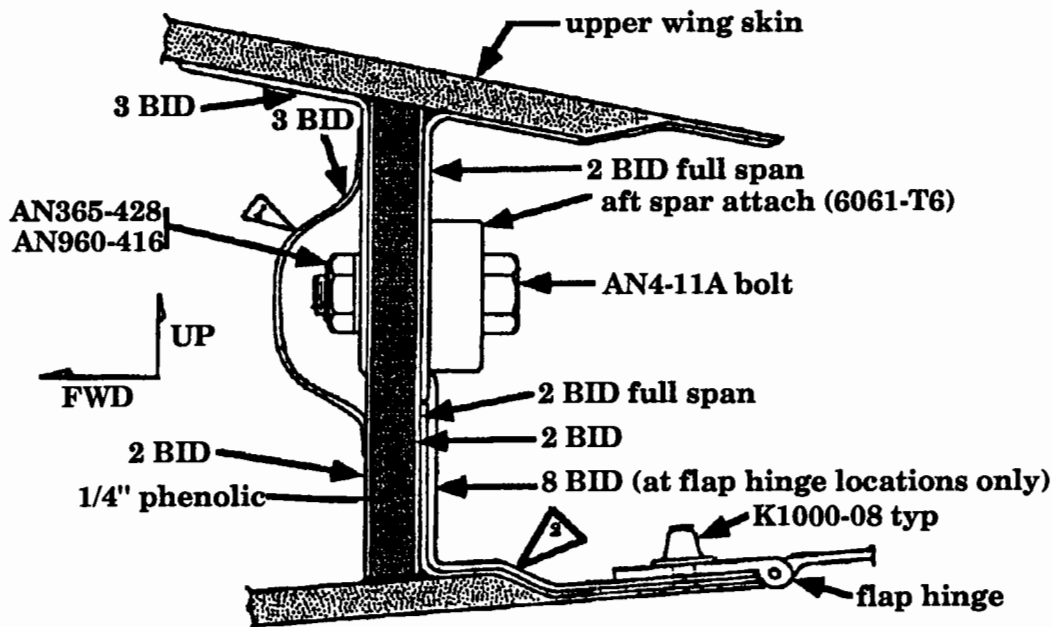

- 1 This 3 BID layup is to form a small cover over the tw aft spar attach bolts. These bolts will extend into the fuel bay and must be sealed off to prevent fuel leakage. Extend this cover inward to the BL 50 rib. If removal is ever required, a small hole can then be made through the BL 50 rib to access these nuts without cutting into the fuel tank.
- 2 When locating hinge section positions on the wing skin, verify that the hinge section will sit FLAT on the skin (i.e., the skin core material must end before the hinge plate starts). If the hinge plate were to ride up onto the core, then the hinge plate would not be flat to the skin line and would be unacceptable. If core material does project into the hinge section positions, cut it back and close out the area with 2 BID.

TYPICAL CONTROL HINGE INSTALLATION

Figure 9-7

Elevator sections.....6.5" per section, 2 sections per side, 4 total required
 Aileron sections.....6.5" per section, 2 sections per side, 4 total required
 Flap sections.....10.5" per section, 3 sections per side, 6 total required

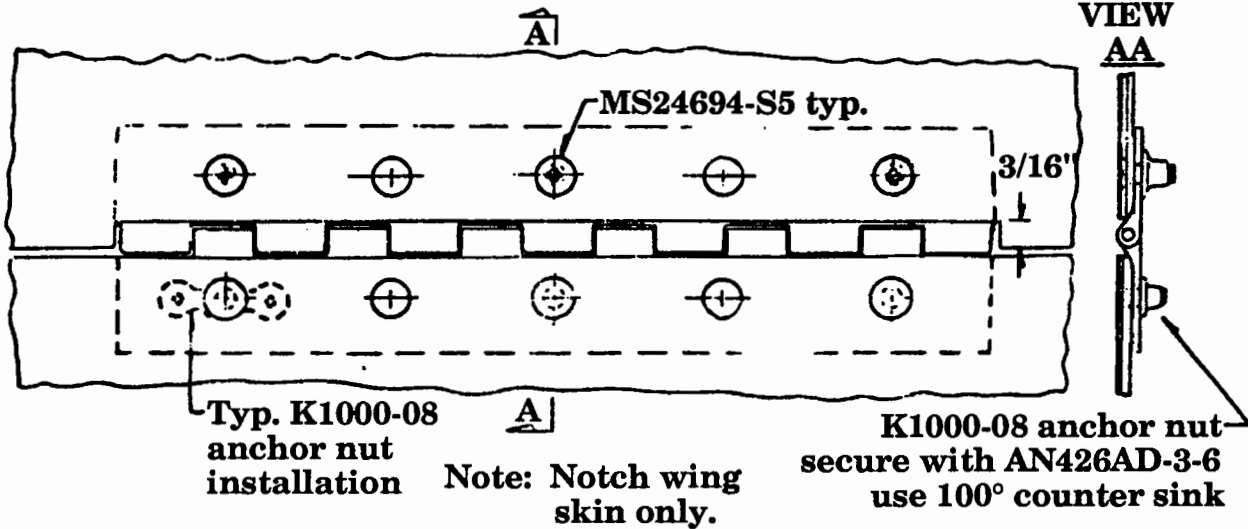

B. BL 105.5 Rib Modification

1. A phenolic hard point must be inserted which will provide the attachment for the aileron bellcrank brackets. See figure 9-8. Remove the 2 BID covering the core on the outboard side of the rib. The phenolic must be inserted from the outbd face of the rib to provide a flat surface on the inbd face for the bellcrank brackets to mate.
2. Remove the core material from the area where the phenolic hard point will be inserted.
3. Prepare the remaining inbd 2 bid by sanding, removing all core material.
4. Using epoxy with 50/50 micro-flox, bond the phenolic hard point into place.
5. Cover the outboard side with 2 BID.



AILERON BELLCRANK ASSEMBLY

Figure 9-8

to edge of BC.

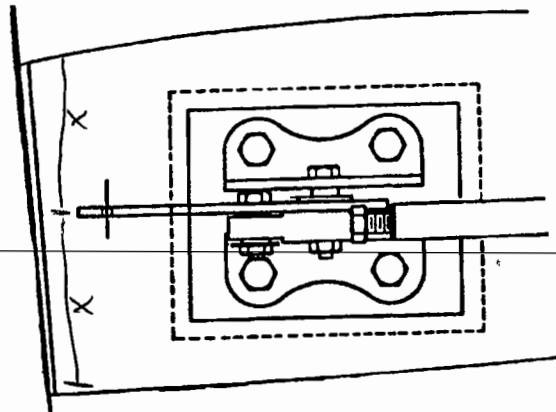
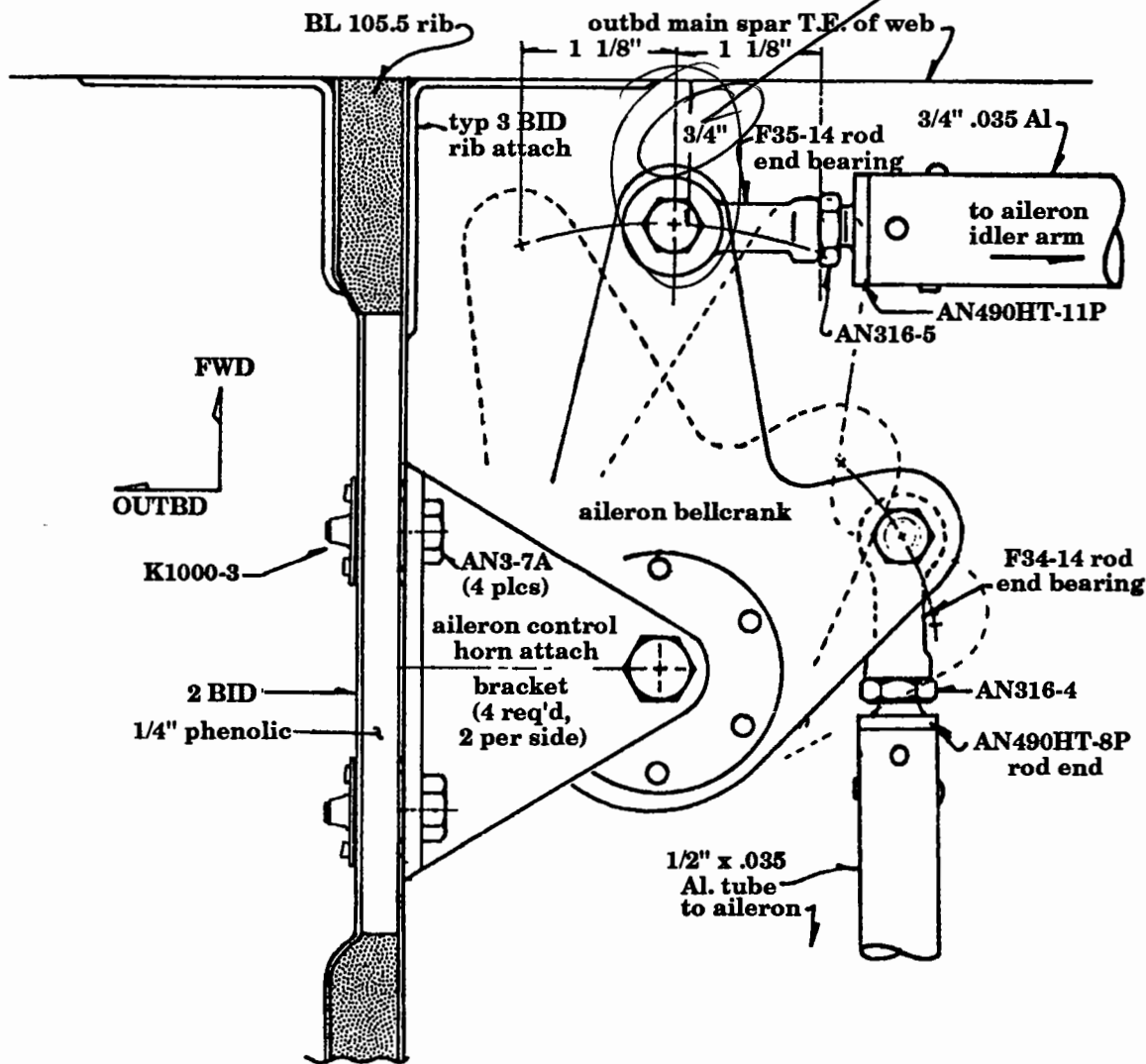

C. Aileron Bellcrank Assembly

The aileron bellcranks will attach to the BL 105.5 rib, onto the hard points you installed earlier.

1. Material for these bellcranks is supplied. It is a piece of .125" aluminum with two 3/4" holes already punched into it which will accept the BC4 bearings. The outline of the bellcranks are also indicated along with the to #12 holes which must be drilled to attach the push rods.
2. Trim the pieces to shape. The shape is not particularly critical, just be sure to use a file to get a smooth final edge with no saw cuts or nicks remaining.
3. It is a good idea to clamp the two bellcranks together when the two #12 holes are drilled. This will assure that the hole centers are the same distance from the rotational center of the bearing position.
4. Attach the BC4 bellcrank bearings using a minimum of six (6) AN470AD-4-6 rivets. Be sure that the bearings sit flat on the surface of the bellcrank. The bearing should be mounted such that it is on the bottom when installed.
5. Next cut out four (4) bellcrank attachment brackets. They are cut from standard pieces in the kit - 1" x 2" x .125" angle aluminum. See figure 9-9.



AILERON BELLCRANK ATTACH BRACKET

Figure 9-9

4 required, all identical.
Make from 1" x 2" x .125"
angle, 6061-T6

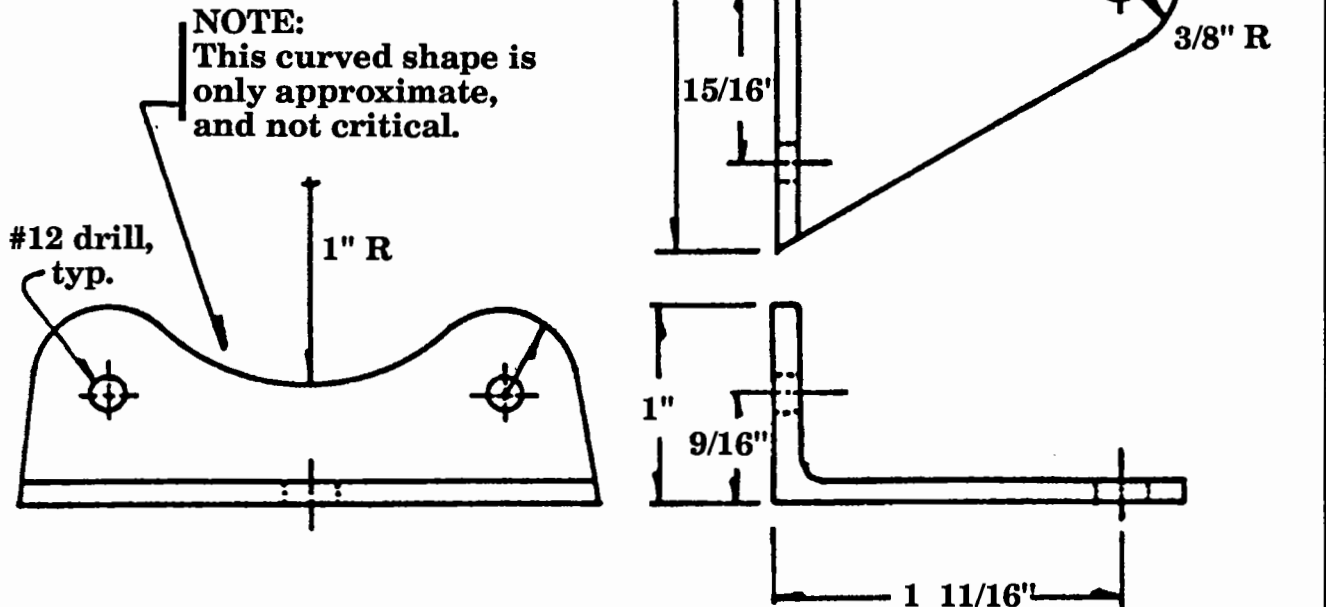

6. Assemble bellcrank with upper and lower attach bracket using the AN4-12A bolt. This should be bolted up tight with the AN365-428 stop nut.

The aileron push rod must transit through the fuel tank area. To do so, your kit is supplied with a thin wall aluminum tube of 1-3/4" diameter. This tube will be installed so as to provide an access through the wing fuel tanks for the aileron push rod. The tube installation must be accurately located to allow full travel of the push rod **WITHOUT ANY INTERFERENCE**.

7. Clamp the aileron bellcrank assembly into position using one or two C-clamps over the BL 105.5 rib section, referring to figure 9-8 and 9-10. The bellcrank should fit about 3/4" aft of the main spar web and vertically at the mid-chord height location.

8. Run the string line from aileron bellcrank to aileron idler arm in the stub wing. This will simulate the aileron push rod center line. This will also require cutting some small holes in the intervening ribs. The push rod's span wise travel is 1-1/8" each way from center, or 2-1/4" overall. Most of the travel of the push rod will be in the inbd-outbd direction but there is some travel in the fwd-aft direction due to the rotation of the outbd bellcrank, and some vertical movement at the inbd end due to rotation of the idler arm in stub wing attachment.

NOTE: When you go to install the tube, you will either have to remove the wing or, what is probably easier, cut a slot in the BL 74 rib down to where the tube will mount, so that you can put the tube through the slot (refer to figure 9-12). Then you can get it into the hole you need in the BL 99.5 rib, and then back into the hole you need in the BL 50 rib. If this is your choice, then you will later have to fill in the slot and replace the 2 BID per side on the rib.

NOTE ALSO: You can also connect the actual aileron push rod instead of using the string. The push rod should be mounted to the top side of the bellcrank so its bearing will (when the aircraft is upright) lay on the bellcrank rather than hang below it (refer to figure 9-11). Again, it might be easier to do this with the slotted BL-74 rib.

Note that the bellcrank assembly is mounted at about a 3° angle on the rib (see figure 9-8). This is to eliminate any interference as it moves through its arc. Be sure before you mount it permanently that you can swing it throughout its entire range of travel without any interference. It can be mounted underneath the bellcrank if necessary, but on top is the method of choice.



AILERON BELLCRANK INSTALLATION

Figure 9-10

Mark the positions of the rib sections. Measure the distance fwd/aft and vertically to the string line indicator. This will provide a good means of determining the position of the transit tube center. If additional clearance is required for push rod operation, the bellcrank itself can be shifted slightly to accommodate.

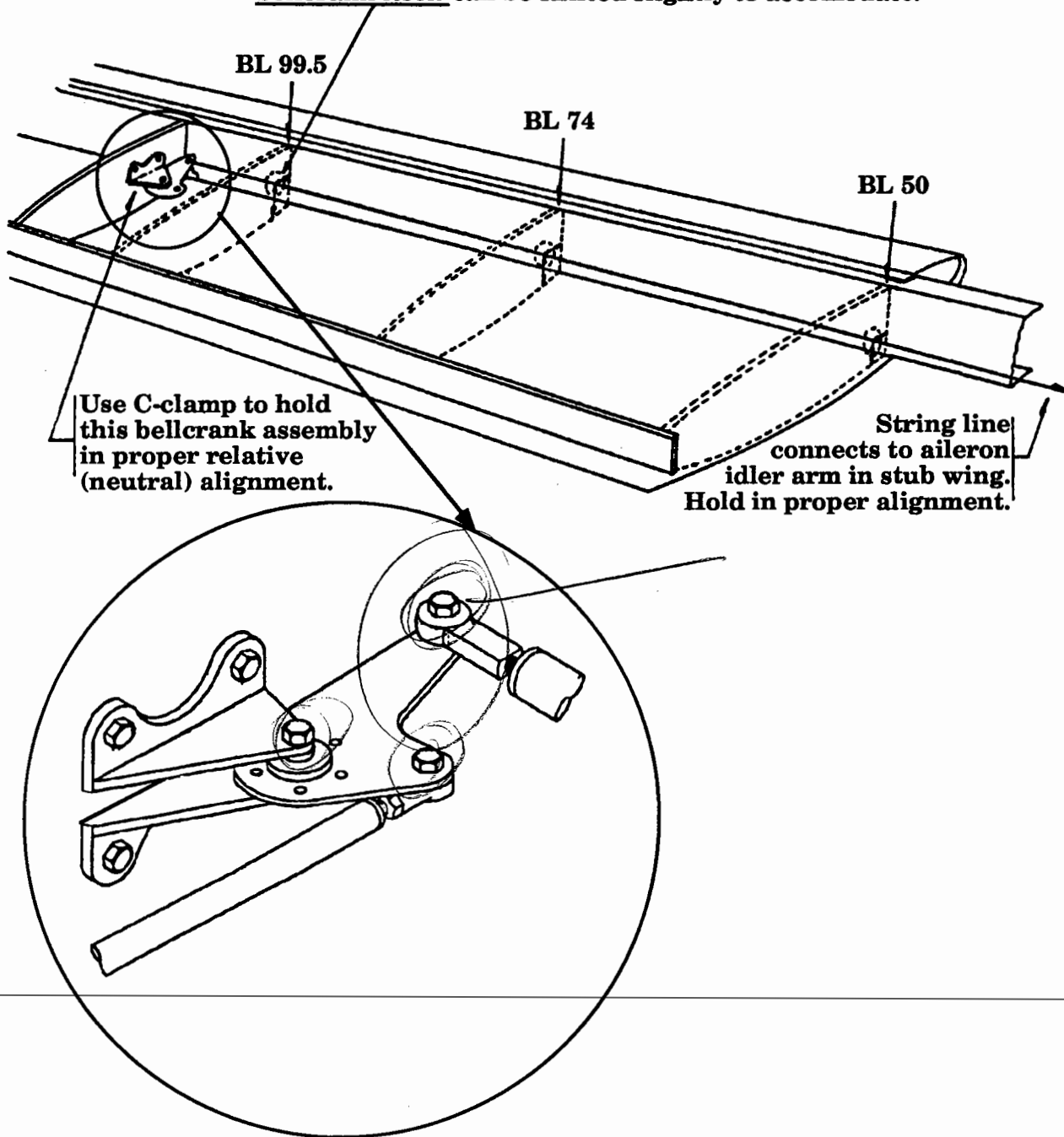

AILERON BELLCRANK ASSEMBLY

Figure 9-11

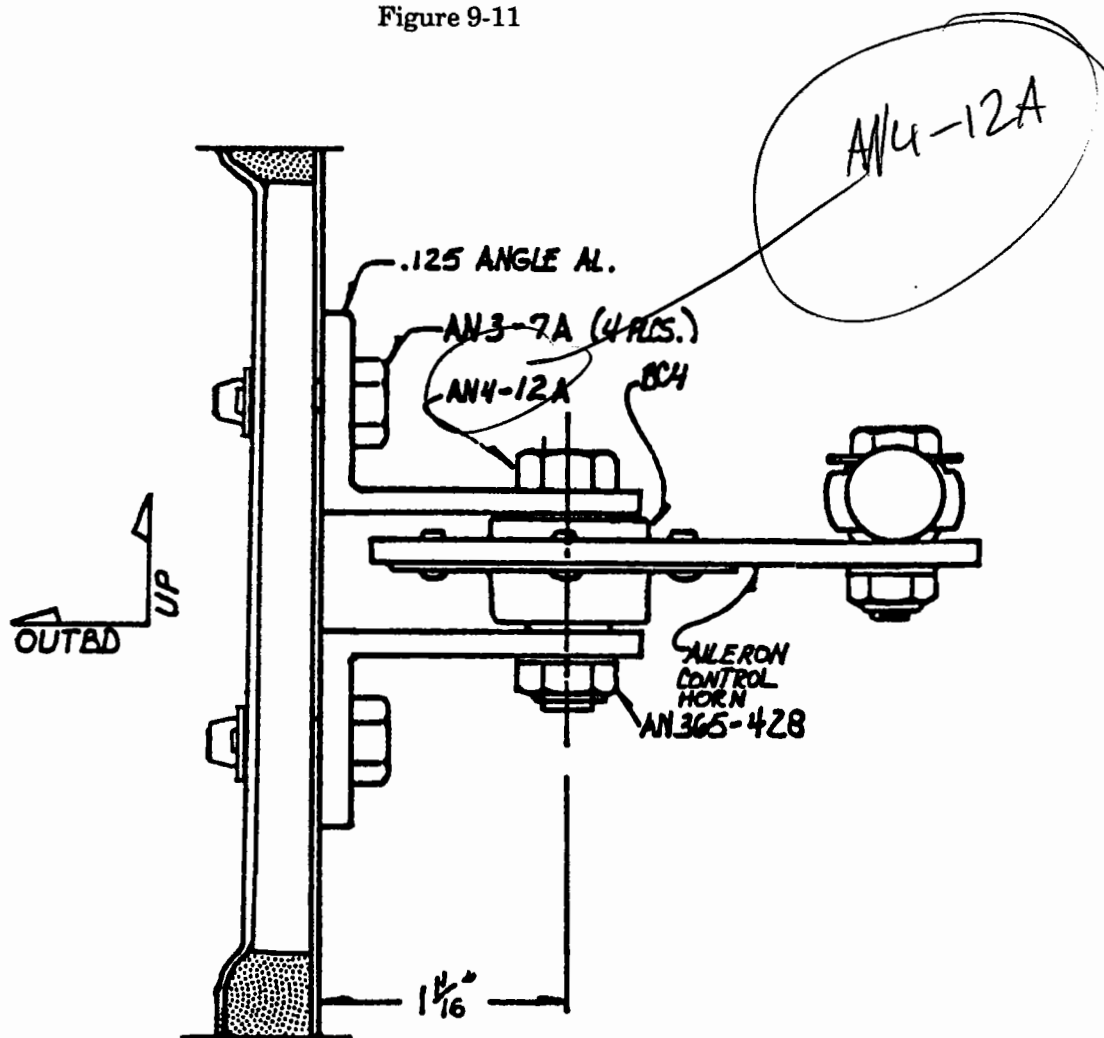

9. If your choice is to cut the slot in the BL-74 rib, do so carefully, and keep the piece you cut out. Using a keyhole saw or coping saw, cut the slot in the BL-74 rib (this will be easier to do if you drill the hole per step 11 first).
10. From the 1-3/4" aluminum tubing provided in the kit, cut to length the transit tube.

NOTE: The transit tube should extend 1/4" - 3/8" beyond the external faces of the fuel tank ribs at each end. This is to provide a surface on each end to make a mechanical bond (BID tapes) of tube to rib on the outside of the tank.

11. Locate the position for the transit tube, and cut the holes into the ribs. You can use a 1-3/4" hole saw to cut the circular holes. If the transit tube requires slight position adjustments for clearance purposes, do so and use micro to fill around the tube as required to seal off the core material.

12. At this point it is best to actually have the push rod to use for a final check. The transit tube and rib assembly will require a preassembly (with push rod slipped into tube) prior to inserting down into the wing. Slip the push rod into the tube and then put the whole assembly into the wing. Connect the push rod temporarily to the bellcrank and idler arm. Check for full rotation per figure 9-8.
If the transit tube must be adjusted, then refit and recheck until clearance is maintained throughout full travel. With full, unrestricted travel achieved, the assembly can be permanently bonded.
13. If you chose to slot the BL-74 rib, now is the time to replace the piece you removed. Using a flat-blade screwdriver or similar, scrape about 3/16" of the core material from the perimeter of the slot, and do the same to the piece you removed.
14. Using epoxy/micro, fill the 3/16" channel in the rib and the piece you removed and, using a little extra micro, re-install the piece in place. A piece of duct tape over each side should hold it nicely until it cures.
15. After it has cured, put 2 BID over both sides of the rib slot, covering the entire piece you removed and extending at least 1 " onto the rib. Let cure.
16. Use micro to pot around the transit tube where it goes through the three ribs.
17. Add 2 BID around the rib to tube junctures. This will require a little patience, as you need to wrap small pieces of glass around the forward side of the tube, since there is very little clearance from the main spar web.

SLOTING THE BL-74 RIB

Figure 9-12

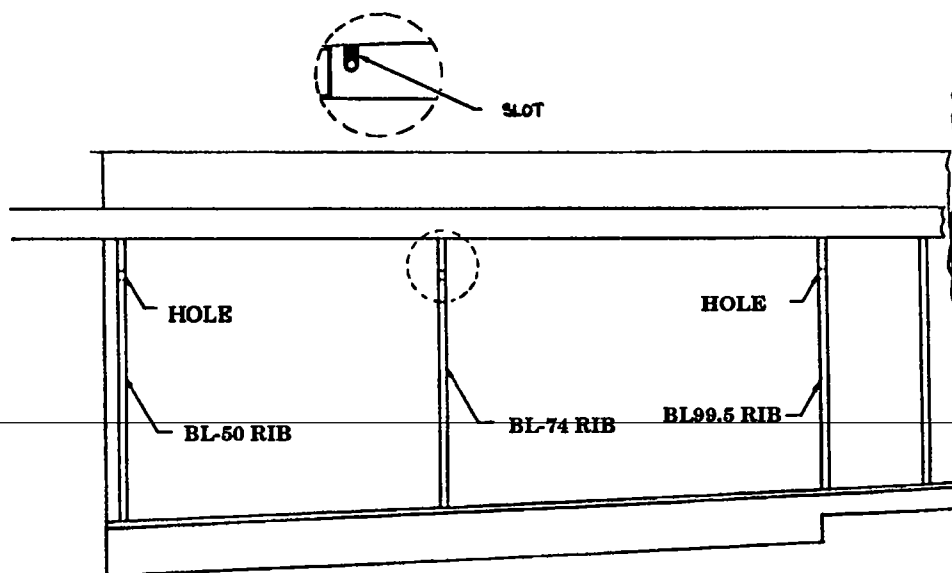

18. Place 2 BID around the rib to transit tube on the exterior side of the fuel tank. Add these tapes to the BL 50 location after the wing is removed from the fslg.
19. Mark the location of the aileron bellcrank bracket attach points on the BL 105.5 rib.
20. Drill the attach holes (#12 bit) through the rib phenolic.

WARNING: Be certain to verify that all four (4) bolt hole locations on the aileron attach brackets are solidly into the phenolic insert in the wing rib. Failure to do so could result in total failure of the aileron controls during flight. Maintain at least 1/4" perimeter in phenolic around all holes.

21. Attach K1000-3 anchor nuts on the outbd side of the rib using the AN426A3-10 soft, flat head rivets trimmed to proper length (see figure 9-8).
22. Use AN3-7A attach bolts to secure the aileron bellcrank assemblies into place.



D. BL 50 RIB MODIFICATION

1. A small phenolic insert must be placed to bond the fuel pick-up line. See figure 9-13. That fuel transfer line is typically a piece of 1/4" aluminum tube (provided you are intending to use the stock fuel system which requires the wing tanks to only "transfer" pump to the header tank). If you intend to run the engine directly off the wing tanks, then the 1/4" line will not be sufficient and **MUST** not be used. Fuel lines directly to the engine must be 3/8" minimum. In addition, such a modified fuel system is much more complicated than it may at first seem. We strongly recommend against altering the basic fuel management without extensive engineering application.
2. Insert this phenolic in the same manner as the one for the aileron bellcrank.



WING FUEL TANK INSTALLATIONS

There are several more items that must be installed into the first two bays of the outbd wing in order to convert this area to a fuel tank. This tank will hold approximately 15 U.S. gallons when completed.

E. FUEL PICK UP LINE

With the standard fuel system, the wing tanks are used only to "transfer" fuel to the header tank where it is fed to the engine. The transfer lines can be 1/4" in diameter. This 1/4" aluminum pick up line must be installed next.

NOTE: If you intend to run the engine directly off the wing tanks, then the 1/4" line will not be sufficient and **MUST** not be used. Fuel lines directly to the engine must be 3/8" minimum. In addition, such a modified fuel system is much more complicated than it may at first seem. We strongly recommend against altering the basic fuel management without extensive engineering application.

1. Cut a piece of aluminum line (1/4" dia 5052-0) approximately 18" long. This will be bent to fit into the bottom of the tank, per figure 9-13, and extend to the fwd lower corner. It then will exit the tank through the outbd BL 50 rib. The exit hole must be through the small phenolic insert placed in the rib. The aluminum line will transition fwd of the primary landing gear attachment where a connection can be made approximately half way between the primary and secondary gear attach points in the center section spar.
2. Drill a 1/4" hole through the phenolic insert in BL 50 (outbd) rib. Use a small amount of 9339 adhesive to pot the aluminum tube into position. Also required is a clearance hole in the inbd BL 50 rib. Allow the 9339 to cure.
3. Add 3 BID around the inside juncture of the rib to aluminum line. Add 2 BID around the exterior side of the rib to aluminum juncture. These can be small pieces of BID about 1" wide. It is easiest to apply these one at a time and wet them out on the part. Leave a generous fillet between rib and aluminum tube.

NOTE: The tube ending on the inside of the fuel tank should be placed such that it is about 1/2" outbd of the BL 50 rib and slightly above the bottom of the tank. It is also recommended that a screen "bag" be made around the end of the tube and bonded to it using structural adhesive. The screen should be about 3" long and about 1/2" - 3/4" in diameter. This will prevent any single piece of contamination from totally clogging the opening.

F. FUEL TANK PICK UP LINE SCREEN FILTER

1. Using a flaring tool or equivalent, flare the end of the fuel pick up line.
2. Make a filter from a piece of brass screen, about the same coarseness as used on the finger filter (16 holes per linear inch), 1/2" - 3/4" in diameter, by wrapping it around a suitable sized marking pen, piece of tubing, etc., overlapping itself by about 1/4". The filter should be about 4" long, minimum. Refer to figure 9-13.
3. Run a bead of structural adhesive down the overlap to seal the seam, and let cure.
4. Slip one end over the pick up tube flare about 3/4", and squeeze/roll the filter to cause it to close down to the tube outside dimension.
5. Apply enough structural adhesive to cover the part of the filter overlapping the tube.
6. Using a piece of fine wire, wrap several turns around the filter and tie it off.
7. Coat the wrapped wire with structural adhesive.
8. Crimp the last 3/8" - 1/2" of the filter flat together, and seal with a little structural adhesive.
9. Referring to figure 9-13, bond the tube to the side of the rib at the location shown using 1 BID to attach.

You now have a permanent screen to filter out any "grimies" that might find their way into your tanks.

FUEL TANK PICKUP LINE INSTALLATION

Figure 9-13

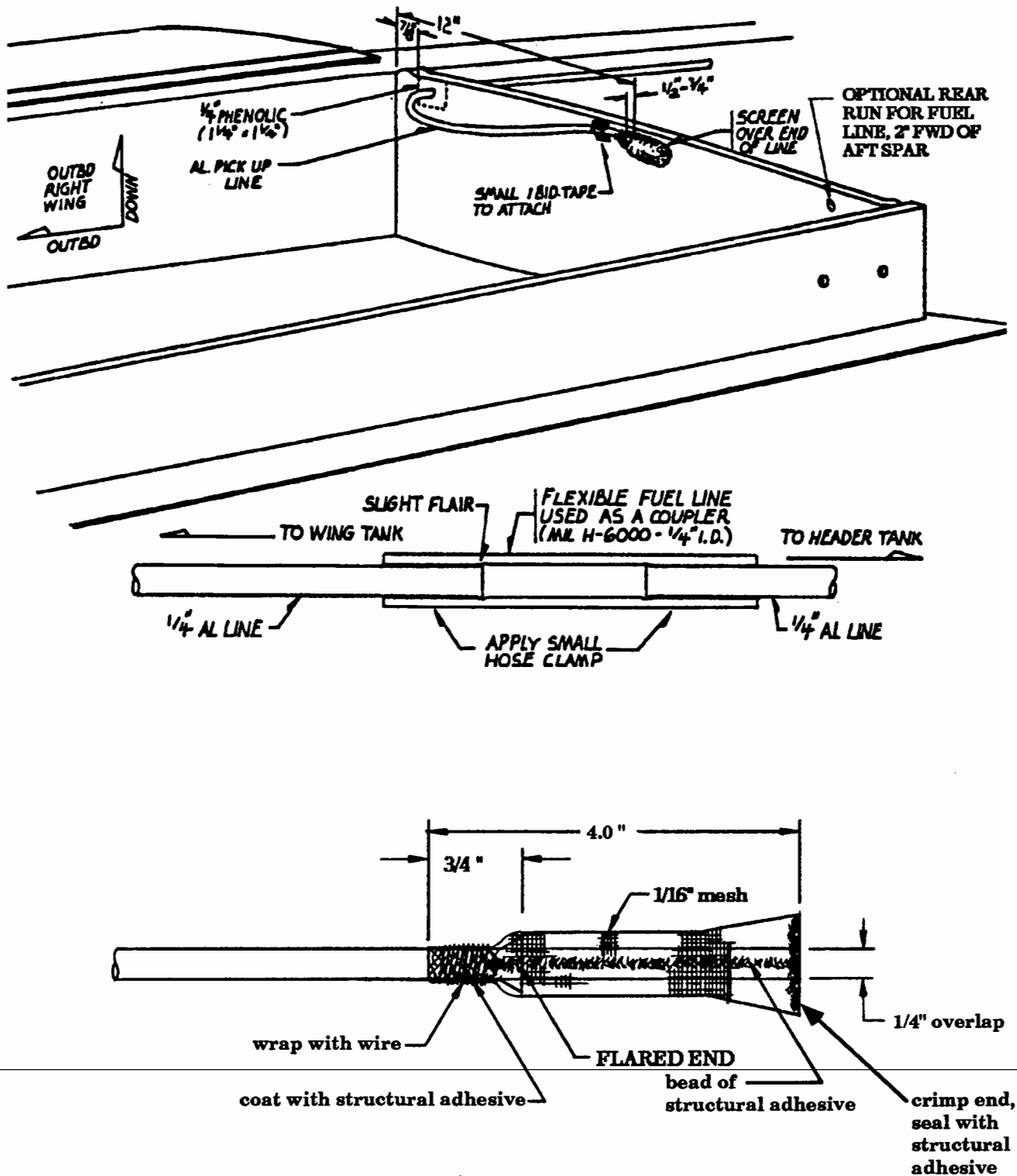

G. Vent line installation

A vent line is required at the upper end of the tank. To help prevent spilling fuel overboard on the ground, the line should be extended just beyond the tip rib. See figure 9-15.

VENT LINE INSTALLATION

Figure 9-14

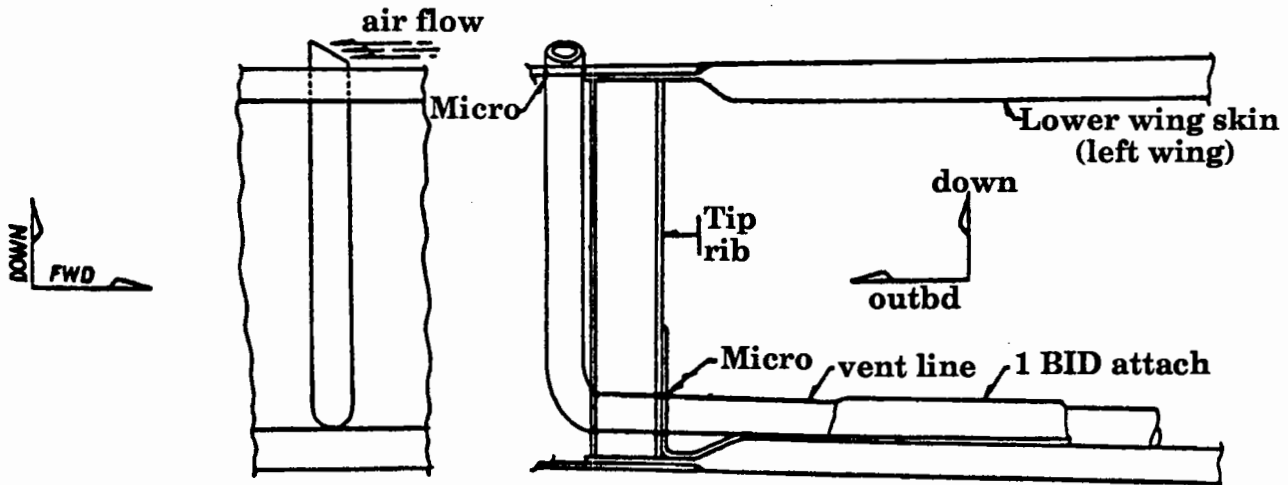

1. The vent line should come fairly close to the fuel tank filler cap and extend outbd. Refer to figures 9-14 and 9-15. Measure the length you will need, being sure to have enough to go from near the filler cap to the tip rib, then bend up to extend 3/8" outside the lower wing skin.
2. Cut it from the 5052-0 aluminum line supplied with your kit.
3. Bevel one end as shown in figure 9-14, being careful to blow out any shavings, etc. that might have found its way inside.
4. Drill the holes through the ribs for the vent line.
5. Slip the vent line into place, bending the outbd end of the tube to shape. A sand or shot bag placed somewhere on the tube should hold it nicely.
6. Place a generous flox fillet around the vent line where it exits the tank and cover with 3 BID. Add 2 BID to the exterior side of the BL 99.5 rib where the line exits.
7. Place a few 1" - 2" long 1 BID tapes to hold the line against the upper wing skin.

H. Fuel tank baffles

The BL-74 rib also serves as a baffle. The cutouts must have the core completely sealed off. Be sure that there are no rough edges that could snag onto contaminants, nor should there be any corner 'pockets' in the tank that could trap quantities of contamination. A span wise baffle could be added, but that is not required.

1. Inspect the tank area for anything that might trap contaminants, and sand off any you might find.
2. Use epoxy/micro to seal off the core in the BL-74 rib that is exposed by the fuel flow slots.

Wing fuel tank

Figure 9-15

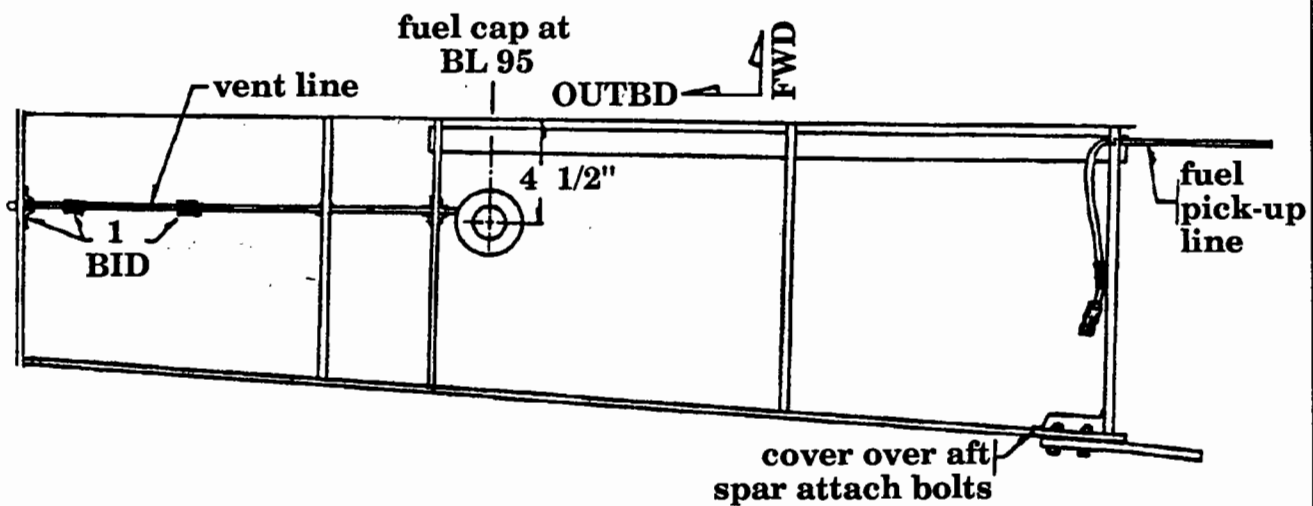

I. Fuel filler cap installation

Your kit is supplied with three (3) filler caps, one for each tank. The Header tank cap is already installed for you, so you can take a look at it for a reference. The installation for the other two is identical in technique.

1. Per figure 9-15, mark the location for the filler cap in the wing skin.
2. Make a circular cut completely through the inner skin, core and outer skin. This diameter should be 2 1/2". Use a hole saw in a drill or equivalent.
3. Next cut a 4 1/2" diameter on the inside skin so that it is concentric with the existing hole. This cut should be made with a rotary type tool and ONLY made through the inner wing skin ply and the core material. See figure 9-16.
4. Scrape away the core and sand a slight bevel into the resultant edge. Be sure to sand all the core away against the outer skin plies.
5. Using 80 grit sandpaper, scuff up the mounting flange on the fuel cap assembly. Note that there is a slight bevel to this flange. Rotate the circular flange until the best curvature alignment is made with respect to the curvature of the upper wing skin itself. Mark this alignment with a pencil on both the flange and skin.
6. Mix up a batch of 9339 adhesive to bond the cap to the inside of the skin.
7. Place plastic tape around the edge of the inner cap and insert the cap in its assembled position. It should be almost flush with the flange (0.030" above is perfect).
8. Spread the adhesive on both bonding surfaces and insert the assembly into the skin.

NOTE: The clamping pressure is very important. It is best to make a curved styrofoam block or equiv. to fit to the outside contour of the wing skin and support it there. Place some weight on the inner side, against the fuel cap assembly to hold it snug against the skin during cure. Use about 10 lbs.

9. With proper weight, and pressing against a well contoured foam block, the cap will end up flush with the surface of the wing. Some 9339 could ooze out, which is why the cap is covered with plastic tape as a release. Otherwise it might get bonded into the mounting ring.
10. After cure, add 2 BID around the inner flange.



Fuel filler cap installation

Figure 9-16

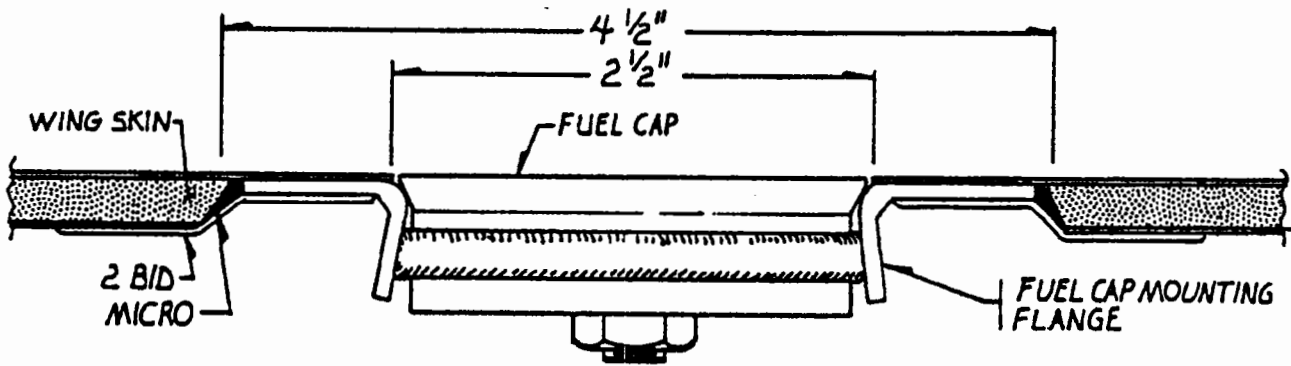

J. Aft spar attach bolt covering

The two AN365-428 nuts which hold the aft spar attach bolts to the aft spar must be covered to prevent possible fuel leakage. Your kit, if shipped after 1/1/90, will contain a pair of spar attach bolt covers. By using these covers as shown in figure 9-17, you will be able to remove the bolts without cutting into the fuel tank, should the need ever arise.

1. Using structural adhesive, and being very careful to use enough to seal but not get any on the threads or nuts, bond the covers to the wing aft spar and BL 50 rib as shown in figure 9-17. You don't have to cut the hole in the BL 50 rib until a need arises to remove those two bolts but in this manner, you'll be able to reach the nuts if required without entering the fuel tank. Thus, this block must go all the way to the BL 50 rib face.

Fuel tank / aft spar bolt cover

Figure 9-17

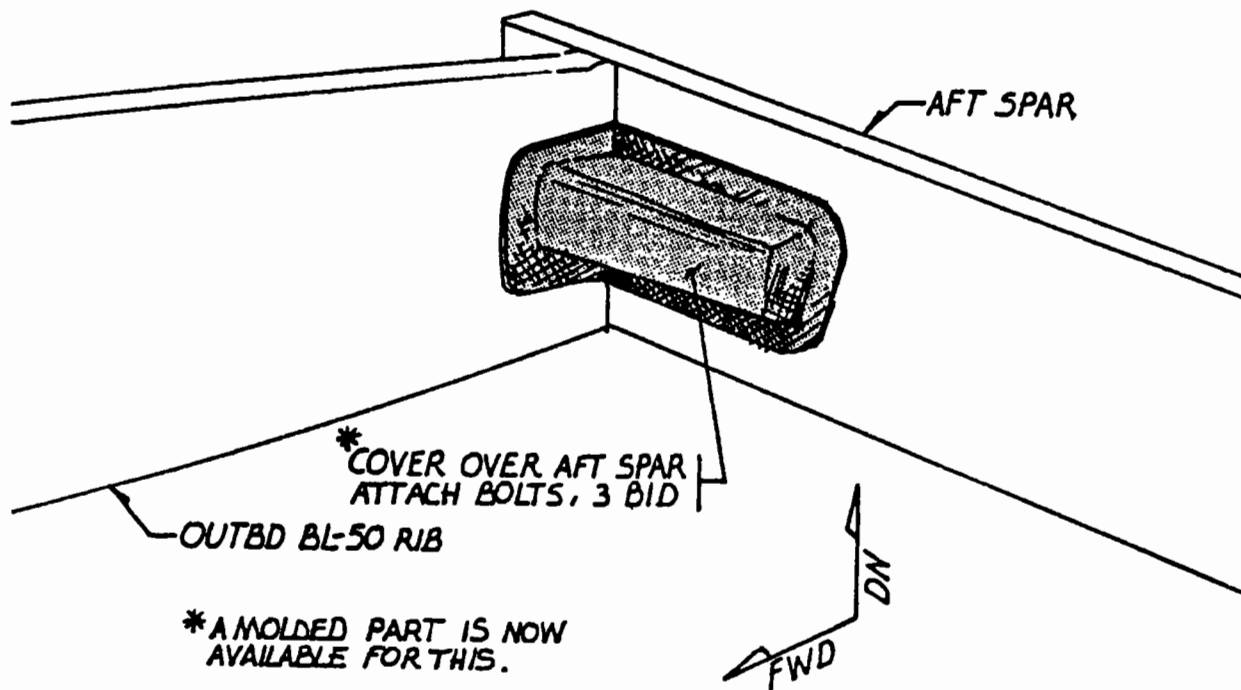

K. Lower outbd wing skin installation

This lower skin will be fitted in a manner used to achieve a perfect fit. The lower skin will be fitted and **released**. Obviously any items which will eventually mount into the wing must be installed prior to closing out the wing. Those items are:

1. Fuel tank completion with sealer, sump drain, filler, vent tube.
2. Wing tip extensions*
3. Extra fuel bay*
4. Nav antenna
5. Transponder antenna** (can instead be mounted in cockpit area).
6. Auto pilot roll control*** (can instead be mounted in cockpit area).
7. Wing tie down points (optional - if you want to use ours, call Neico now for the parts so you'll have them when it's time to install them - on page 9-40).

*If you are considering the extra fuel bay or wing tip extension options, contact Neico now so you can have the information on hand later when you will need to make the final decision (about page 9-39).

**Suggested mounting area is in the belly or aft compartment, providing several benefits - no disconnect to remove wings, shorter lead lengths, easier access.

*** If you want to install the auto pilot roll control in the wings, contact Neico for the optional blueprint that outlines this installation. Call now, so you'll have it before time to close out the wing.

We will go through the sequence to prepare the wing for sealing, and then, prior to closing it out, go over the above list again.

1. First trim the L.E. of the lower wing skin where it will **BUTT** to the "D" section of the upper wing skin (over the lower spar cap). This is a 1-1/2" joggle, but not a critical dimension.
2. Fit the lower skin into position and mark for the BL 50 trim line. Note that since the ribs and aft spar are probably a little high, the skin will set loosely over them and a close, accurate alignment will not be possible. That will be o.k. for now.
3. Check the wing tip alignment joggles and align with the upper wing skin joggle.
4. Drill the 1/4" hole to let the fuel tank vent line protrude.
5. The BL 50 rib (on the outbd wing section) can be sized directly off the skin line generated by the stub wing. The rib will be 1/16" below contour to allow for the wing skin thickness of the outbd lower skin.



6. The wing tip rib is similarly sized (this should have been done already, but it wouldn't hurt to double check against the blueprint).
7. Since the BL 50 rib at one end and the tip rib at the other end are sized, and since the wing is a straight taper, the ribs between can be sized by simple use of a long straight edge spanning from BL 50 rib to tip rib (refer to figure 9-18). The ribs can be quickly sized down by using a 4" electric hand grinder. Be careful, since these grinders cut fast.

NOTE: It is important that when laying the straight edge across the ribs to establish sizing, **YOU MUST BE AT SIMILAR STATIONS ON BL 50 AND TIP RIBS** (i.e., if you are at a 30% of chord station on the BL 50 rib, be at a 30% of chord station on the tip rib, which will be a shorter linear dimension since the rib is shorter).

This % of chord is not too critical however, just be "eyeball" close. This above method is good enough to get quite close in dimension. **HOWEVER, the 1/4" - 5/16" core material thickness must also be accounted for. You must subtract 1/4" - 5/16" additional along the inner ribs where they contact the core material.**

Trimming ribs

Figure 9-18

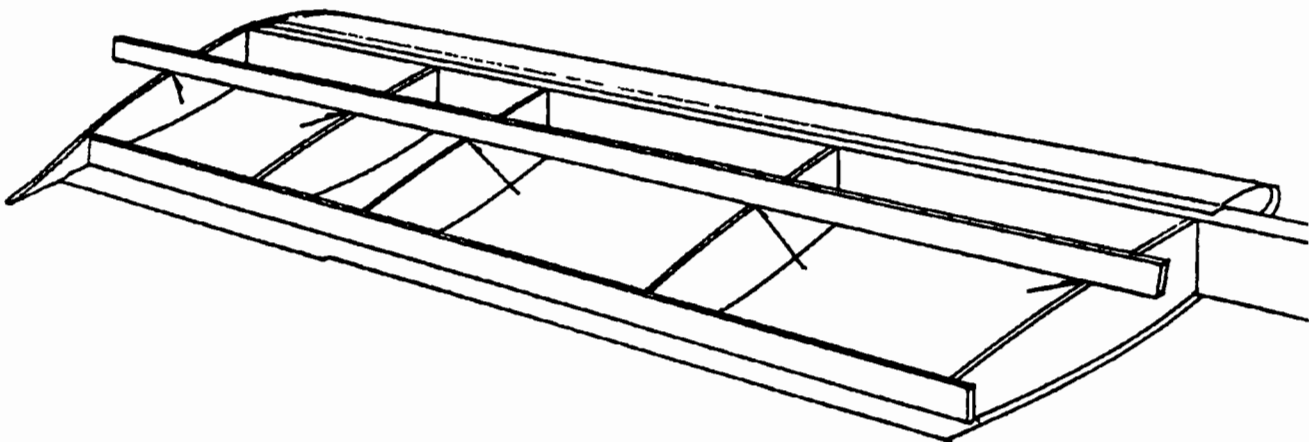

8. With the ribs sized fairly close, lay the lower skin into position and check for contact and interference by lifting the skin very slightly at various points and sighting underneath.

9. Two or three "fit checks" and adjustments will usually get the ribs and aft spar sized correctly. Be sure that you don't get too much crown left into the lower surface. The lower wing skin tends to curl back away from the mold slightly, thus inducing additional curvature. This is very easily taken out provided the ribs will allow it to be taken out when bonded. Again, a straight edge over the skin, when laid in position, will tell the story.
10. When the ribs are fully sized, check them against that straight edge placed along the full span of the outboard wing section. The clearance dimensions between straight edge and rib surface should be fairly constant from rib to rib.
11. Prepare the edges of ribs for a compression bond by scraping back the core to expose about 1/8" of surface ply on both sides. You will fill this "trench" with epoxy/micro.
12. Mark off the inside of the lower skin where all ribs will be contacting it and cover those areas with plastic packing tape. It will serve as a "release". Tape should extend at least 1" in both directions from the ribs.

Note: The next 5 steps have to be done in the working time of the epoxy you will mix, so be sure you mix enough for the amount of the job you intend to do. You will be putting micro into the channels of the ribs, and putting a 1 BID layup onto the lower wing skin, then putting it all together so that it can cure as a unit.

13. Prepare a 1 BID tape for each rib, that will be 1 1/2" wide and as long as the rib.
14. Place the BID tapes on the inside of the lower wing skin such that it will be centered over their respective ribs when the skin is in position.
15. Mix up and apply a generous amount of epoxy/micro to all rib channels, sufficient to fill the channel and just a bit more to give a good bond.
16. Lay the lower wing skin into position and weight it down to proper contour. A straight edge can be clamped along the T.E. Use plenty of weights over the span of the skin. You need approximately 100-150 pounds.
17. **RECHECK YOUR WING TIP INCIDENCE BY CHECKING WITH A WATER LEVEL. SUPPORT THE WING SO THAT WHEN ALL THE WEIGHTS ARE APPLIED, NO BOWING OR TWISTING RESULTS.**

Now allow to cure.

18. After cure, remove the weights and remove the wing skin.

19. Trim the rib caps so that they are about 1-1/2" wide, and extend over each side of the ribs evenly. A heat gun and sharp knife works good for this.

20. Clean off any excess micro that may have squeezed out with either a utility knife and heat gun, or grind it off.

21. Make sure full contact was made over length of ribs. Any spots where the 1 BID tape is not fully bonded will be taken care of in the next step.

22. Using epoxy/micro and a modified tongue depressor, make a 1/4" radius fillet between the rib caps and the ribs as shown in figure 9-19. As you do this, inspect all BID for voids between BID and rib, filling with micro as you go along.

23. Prepare 2 BID tapes to be used as shown in figure 9-19. These tapes will go on both sides of each rib, extending from the edge of the cured rib cap, down across the micro fillet, and onto the sides of the ribs.

24. Use your brush to "stipple" the tapes into place, removing any trapped air from beneath the tape. Use care here - you could add a lot of weight that isn't necessary at this point by leaving excess epoxy. Use only what is necessary to wet out part and get a good bond.

Rib caps
Figure 9-19

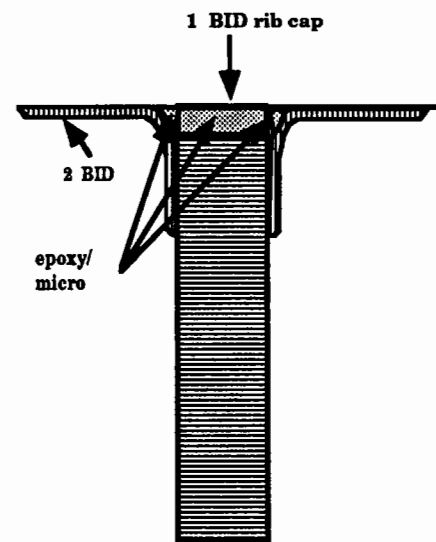
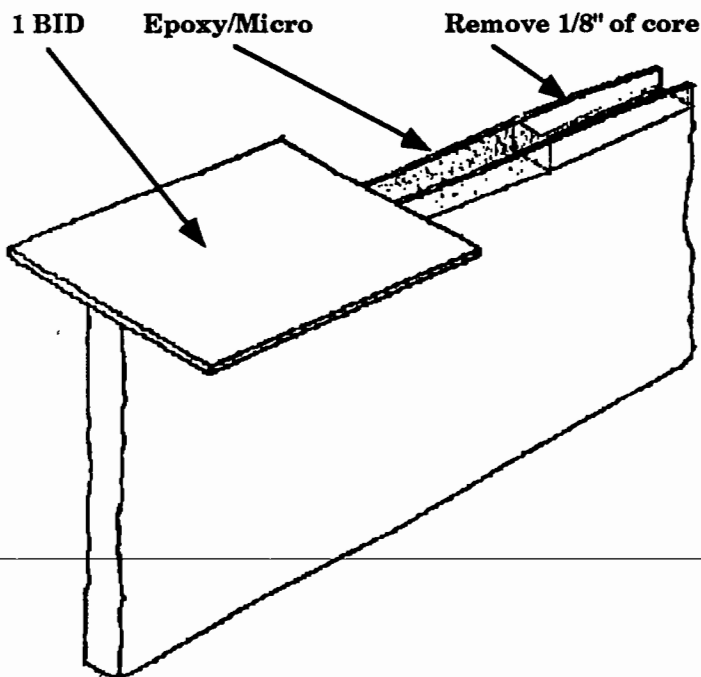

The lower wing skin and ribs are now prepared to fit nicely together, but we still have some unfinished business to attend to before closure;

NAV and Transponder antennas - If you are going to mount these in the wing instead of the fuselage, proceed at this time to the ANTENNA INSTALLATION SUPPLEMENT, and perform those steps, returning to here when finished.

Auto Pilot Roll Control - If you are going to mount the roll servo in the wing instead of the fuselage, refer to the drawings you got from Neico when you called them back on page 9-35, and do those steps now, returning here when you are finished.

Wing Tie Down Points - If you've decided to install these, now is the time. Proceed with the instructions starting below.

If you have finished with all of the above considerations, all that is left is the **sump drain installation** and wing closure. Proceed to page 9-42, and get back to work.



L. Wing tie down points (Optional Pcs)

Wing tie down points can be installed in a variety of ways. This will describe installation of our tie down rings, available as an option. See figure 9-20. It is best to have the lower wing skin fully fitted (but not bonded) before installing the tie down plates.

1. Locate a position on the aft face of the outbd main spar. This position is not critical. If it is located between the BL-99.5 and BL-105.5 ribs, then there will be access to it after the wing is sealed. However, there is not much reason for access. When positioning this plate, note that adequate clearance must be maintained from the aileron push rod through full travel.
2. Note that the barrel length of the receptacle is set by the manufacturer such that the locking pin must be tight against the barrel in order for the locking "balls" to engage. This surface plane must be in alignment with the lower outside wing skin surface. Therefore the barrel must extend through the 1/4" thickness of the skin core.
3. Grind the flat plate back such that the barrel does extend 1/4" beyond the plate.
4. Drill the flat back plate with several holes (1/4" dia. is sufficient). This is to provide flox penetration. The hole pattern is not critical.

Wing tie down installation

Figure 9-20

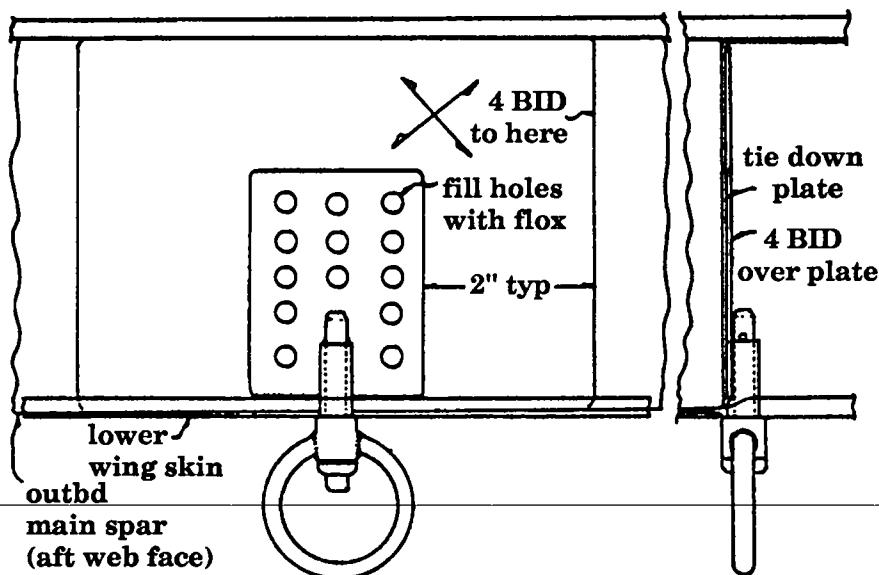

5. Position the plate against the back of the main spar web. Locate the barrel such that it extends about 3/16" - 1/4" beyond the spar cap lower surface. You may have to file the barrel down slightly after the skin is attached but it is better to have the pin net out a little long for the barrel (thus an easy engage of the lock pins) than to have the final assembly of barrel and skin total something that is a little too long for the pin (thus not allowing the lock pins to engage at all).
6. Attach the plate to the web with epoxy/flox and 4 BID over it. Contact 2" onto the spar web all around. Use a couple of small dabs of hot glue to hold the plate in position or simply clamp it with flox only and later add the 4 BID.
7. When you refit the lower wing skins, you'll have to mark and drill for the barrel hole through the skin surface. This is a 3/8" hole.
8. If the barrel protrudes beyond the surface of the skin, simply file until it is flush with that surface. Don't file for this alignment until you have bonded the lower skin into position to verify the surface level. Also note that there is usually a small amount of micro filler required to fair the lower surface contour in with the fwd "D" section through the 3" BID tape area over the spar cap - allow for this dimension as well.
9. If when you are finished, you have a difficult time engaging the lock pins when inserting the tie down ring, it is probably because the pin is not getting deep enough into the barrel. Relieve the skin surface as required.



M. Fuel tank sump drain installation

1. After the lower outbd wing skin has been fitted, the sump drain block (#FU3, supplied in your kit), which is drilled and tapped for 1/8NPT, should be installed into the lower wing skin per figure 9-21.
2. Per figure 9-21, bond the 1" square block to the lower outbd wing skin. Be sure that the pipe threads are properly oriented so the taper decreases towards the inner side.
3. Place 3 BID over this block.
4. Use either an F391-18 flush drain or the Curtis type quick drain. The flush type is preferred.
5. A nice fairing can be easily made to fair in the head of the drain on the exterior of the wing. Place a socket over the drain and put micro around it. Wrap the socket with plastic tape first so it will release. Remove the socket after the micro cures and sand it to a smooth fairing around the head of the drain. This automatically provides adequate clearance to slip the socket on for installation and removal.

Fuel tank sump drain installation

Figure 9-21

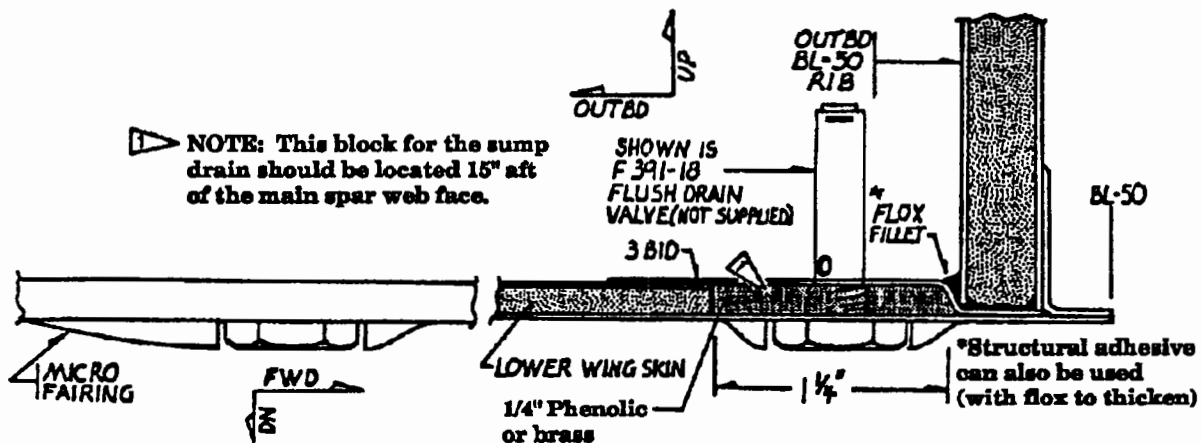

N. Aileron inspection panel

One aileron inspection panel is required in each outbd wing. See figure 9-22 for size and location. The method of construction is as follows.

1. Using a sabre saw, cut out the panel completely through the skin.
2. Place plastic tape over the inner skin of the panel and replace the panel in the skin.
3. Hold the panel in position with tape or mixing sticks held down with hot glue.

Aileron bellcrank inspection access panel

Figure 9-22

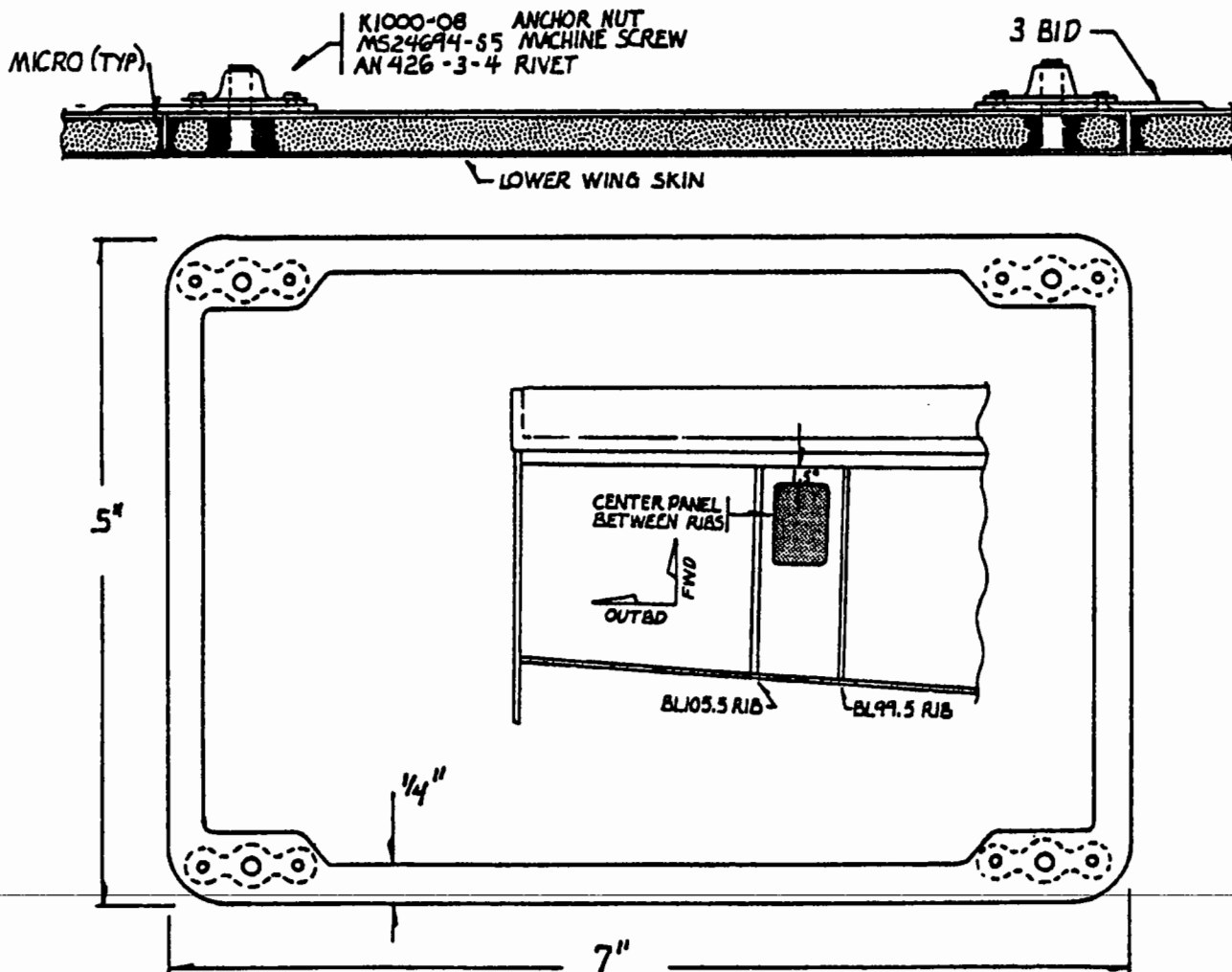

4. Add a 3 BID tape around the perimeter on the inner surface. It will contact about 3/4" onto the wing skin and hang over the panel by about the same 3/4".
5. After cure, remove the panel and trim the 3 BID down to a 1/4" width except for where the anchor nuts are installed. Make those 4 areas larger as required to mount the K1000-08 anchor nuts.
6. Scrape the foam back in the wing skin and fill with micro.
7. Drill a #19 hole for the 4 attach screws. From the inner surface of the inspection panel, grind out the core material around the holes and fill with micro from the back. Allow to cure. After cure, redrill to the holes and countersink with a 100° countersink. Attach with 4 MS24694-S5 screws.

NOTE: IF YOU ARE GOING TO INSTALL THE WING TIP EXTENSIONS, DO IT NOW, and return here after completing the instructions in the wing tip extension supplement.

O. Fuel tank sealer installation

There are several methods of sealing an integral wing fuel tank. The following is one method which works well. It will utilize PRC 1422A fuel tank sealer and #420 primer. We have used PRC 1422A with #420 primer in our aircraft and to date have had no bad effects from it's use. However, as with any after market products, Neico can not warranty them beyond any manufacturers warranties, disclaimers, etc.

NOTE: If you use this tank sealer, it should not be painted in until the lower wing skin has been completely fitted and is itself ready to be bonded into permanent position.

PRC 1422A and #420 Primer Installation

1. There are two parts to the process. First is a primer which, even from PRC engineers, is in debate as to it's true need. However, we generally use the primer. The second is the actual sealer.
2. Clean and prepare the tank interior in the usual manner as you would in preparation for any fiberglass wet layup.

WARNING: These materials are very toxic and require good ventilation. A good charcoal respirator mask should be used along with protective gloves.

3. Carefully mask off ALL the areas where the lower skin will bond to the wing. Use masking tape on the lower skin.
4. Mix the #420 primer. It is a two part system that is a bright orange in color.
5. Paint the sealer onto the inner surface of the lower wing skin using a wide brush. You will need to use a smaller brush to coat the ribs, up under the BID caps. Allow to cure for 24 hours. This will be a highly "tacky" surface. You may, depending on where you are building the plane, want to cover it to keep out the bugs, dust, or other things that may be circulating in the air.
6. Next mix the 1422, **but only in small batches.** The 1422 will cure rather quickly so only small pint batches should be used, one at a time. It is also a two part system and very toxic.
7. ~~The 1422 is very thick and can be thinned with MEK or Toluene (the second is better, the first is easier to locate, and both are toxic). MEK in particular will accelerate what is already a pretty fast curing material so be completely ready when you mix it and work quickly. Dilute only by 10-15%.~~

8. Brush and / or squeegee the 1422 over the tank interior surfaces. Cover all surfaces with a smooth coat. Allow to cure for 24 hours (it will still feel tacky and will continue to feel tacky for weeks - that's o.k.).
9. Apply a second coat of 1422 and allow to cure for 24 hours.
10. Remove the masking tape which was a barrier from both the lower wing skin and the wing.
11. Check that the vent and pickup lines are clear and not filled with sealer. Check that the pipe threads for the drain are clean.



P. Final closeout of lower wing skin assembly

1. When you are ready to bond the lower skin into position, coat all surfaces with 9339 structural adhesive, and use it **generously**.

IMPORTANT: Apply the 9339 over the top of the tank sealer by about 1/8" on the lower wing skin surfaces where the masking tape was applied. This will assure a fuel proof surface since all surfaces will be covered with primarily sealer but also 9339 adhesive along these taped off positions.

2. Position the wing skin and apply weights to hold position. The weights and clamping procedure should be similar to that used when setting the micro and the rib caps.

RECHECK YOUR WING TIP INCIDENCE WITH YOUR WATER LEVEL. AFTER THIS THING DRIES, THERE WILL BE NO CHANGING IT. SUPPORT THE WING SO THAT WHEN ALL THE WEIGHTS ARE APPLIED, THERE IS NO BOWING OR TWISTING.

3. ALLOW TO CURE.

4. After the skin has cured in position, remove the weights, prepare the L.E. joggle (over the lower spar cap) and add 3 BID along this joggle. They should be 3" wide.
DO NOT RUN THESE BID TAPES OVER THE JOGGLED AREA WHERE WING TIPS WILL ATTACH. STOP SHORT OF THAT FWD-AFT TIP JOGGLE.

5. Remove the aft spar attach bar and remove the aluminum shim that represented the BID you are about to install.

6. Add 2 BID along the entire wing T.E. where the lower wing skin meets the aft face of the aft spar. These 2 BID will run from where the 2 BID attaching the upper wing skin to the aft spar stops, across the remaining half of the aft spar and across the lower wing skin as shown if figure 9-6.

7. Apply 8 BID additional where the flap hinges attach, refer to figures 9-2 and 9-6. You can easily add these additional BID immediately after applying the 2 BID attach tapes.



Q. Flap hinge positions on lower outbd wing skin

Refer back to page 9-9, fig. 9-2. There are three flap hinge locations. These hinge sections each measure 10-1/2" long. Similarly to the aileron hinges, the hinge sections must sit flat on the surface of the skin, there must not be any core material interference. Core material can be removed if necessary. Remove only as much core as is required.

1. Per fig. 9-23, locate the flap hinge positions onto the lower wing skin surface.

Flap hinge installation

Figure 9-23

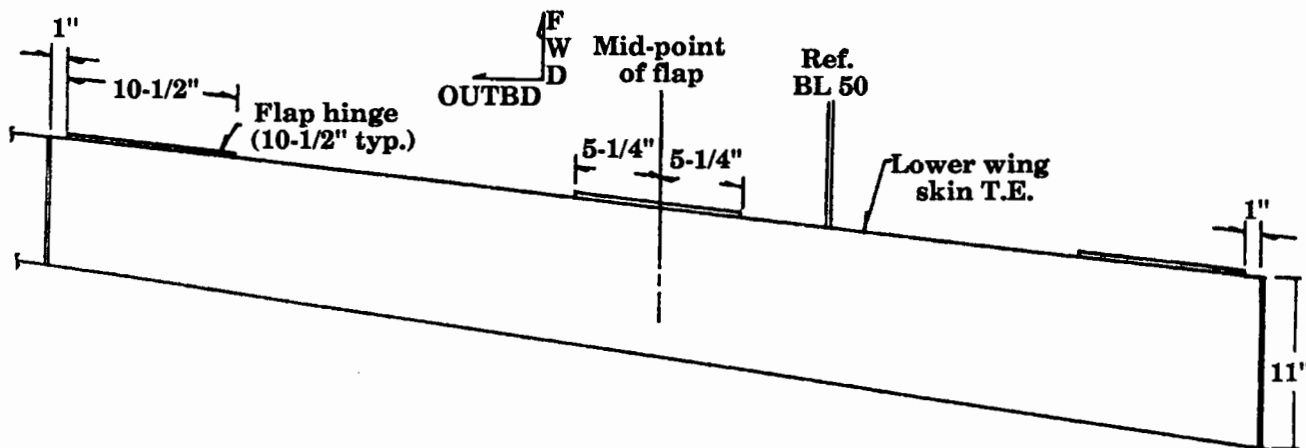

2. Per fig. 9-2, (page 9-9) mark out the trim line of the lower skin T.E. and trim to size.
3. Prepare the surfaces and add 8 BID. These BID must run fully to the skin T.E. and also 1-1/2" up onto the aft web face. At the location of the aft spar attach bar, run up to the base of the bar thus not affecting its alignment.
4. Make the notches into the lower skin to fit the hinge sections, see figure 7-10, page 7-15 for typical hinge installation into a skin. A rotary tool cutter with a small circular cutter works well for this notching procedure.

R. WING TIP INSTALLATION

The wing tips are a two part assembly (upper and lower). They are designed to install over the wing tip joggle on the wing skins. The standard approach is to make a permanent bond. It is possible to make the tips removable but that will require considerably more work with no real advantages.

1. You'll need the wing tip jig to locate the correct T.E. position for the tip so set the wing up with this jig in position.
2. First trim to approximate size. The outbd joint line has a 1" joggle in it.
3. Fit the upper part into position and temporarily set with one or two clecoes. It will fit over the tip rib and up to the outbd edge of the aileron. Leave a 1/16" gap at the aileron.

The tip rib T.E. may require additional size reduction in order to fit the wing tip smoothly.

Wing tip installation

Figure 9-24

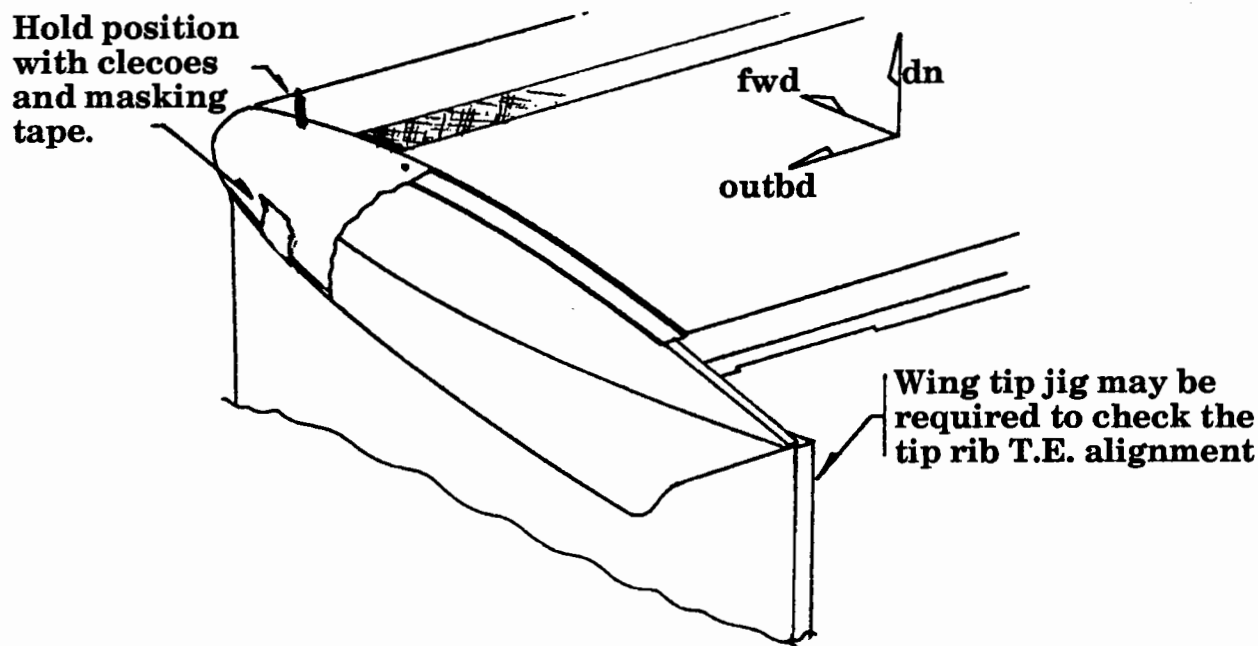

4. Fit the lower portion of the wing tip by butting it to the upper tip and fitting into the joggle of the lower wing skin. Use a couple of clecoes to hold position on the lower wing skin and pcs of duct tape to hold outbd and T.E. tip alignment initially.

NOTE: The T.E. of the wing tip will be approximately 3/32"-1/4" thick. That is because the aileron itself will be made with this 1/4" thick T.E.

5. When the fit onto the wing and the upper/lower tip alignment is satisfactory, apply a 2 BID tape around the perimeter where the joggle is. This joggle should be sanded down first to remove the primer.

NOTE: It may be easiest to add a couple of small 1 BID strips (1" long) to initially hold alignment. Then remove the duct tape and apply a 2 BID strip full length.

6. With the wing tip halves bonded together on the outside joggle, remove the tip. Add 1 BID along the full inside seam. Allow to cure.
7. With the tip now as one piece, a clear wing tip lens for lights can be installed. It is also possible to mount the external lighting system.
8. After any lighting requirements on the wing tip are met (see following discussion and installation), the wing tip can be permanently bonded into position using preferably structural adhesive. It is best to simply clamp the tip in position during the bonding process or lay the tip in the wing tip fixture and weight it from the bottom thus generating uniform pressure all around. The T.E. where it aligns with the aileron can be taped during the bond.



S. Wing tip lighting

Some discussion of available wing tip lighting packages is now in order since installation approaches will be affected.

Without doubt, the easiest (by a significant margin) lighting approach is with our optional three in one Whelen lighting kit (Type 1 lighting kit). This Whelen A-600 assembly incorporates all the FAA required lighting and anti-collision light requirements into a pair of externally mounted housings. They are excellent and are as light as anything you could install. They also are fully on the exterior of the wing and some builders do not like those things protruding from the wing tip. From a drag standpoint, it is a very small penalty in increased parasite drag, probably not measurable on an airspeed indicator. But granted, it is not the most attractive approach to lighting and our builders are often quite conscious of the appearance of the Lancair. That appearance, after all, played a sizable role in their decision to build in the first place.

For that reason, we have developed a much more "flush" lighting system also using Whelen light modules. It too meets all FAA requirements. With this second system (Type 2 lighting kit) the position lights (red / green) are buried beneath clear lenses in the wing tip, a strobe lens protrudes from the central area of the wing tip edge. A standard tail light is attached to the rudder. Our first production Lancair 320 has small tail lights flushed into the T.E. of the wing tips thus two tail lights (Type 3 lighting kit). This is a very attractive package and a lot of work.

Cost? The all in one (Type 1) and the flush system with rudder tail light (Type 2) are comparably priced, the third described with molded T.E. tail lights (Type 3) would cost a bit more primarily due to the addition of one extra tail light assembly.

If you are not installing lights or installing the all in one (A-600) unit, then the tip can be bonded on and the lights installed afterward. For that reason, we'll now discuss the flush mount system (Type 2).

TYPE 2 - Wing tip lighting

Figure 9-25

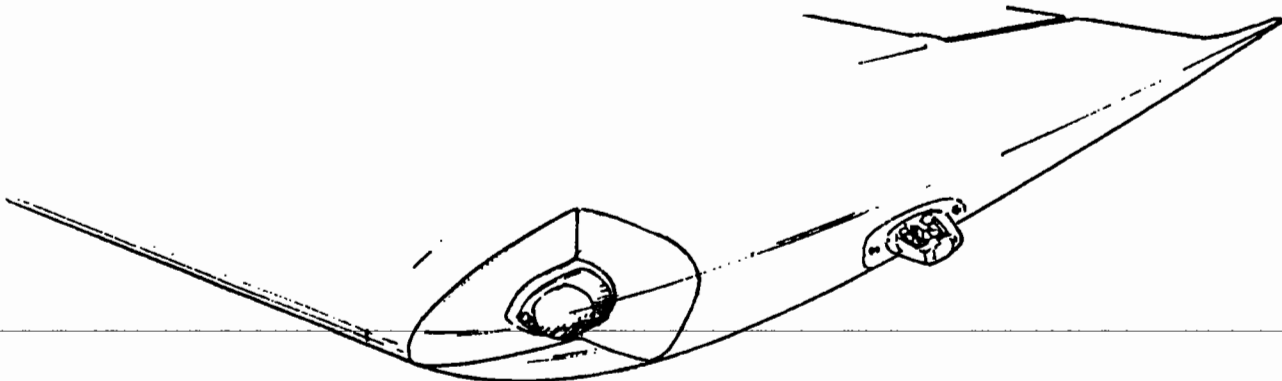

1. Select the wing tip lenses (clear) and unwrap them.
2. See figure 9-26 and locate the trim lines on the L.E. of the wing tip. Mark them on with a marker pen.
3. Hold the lens over the tip and sight downward. In this manner, you can align the lens (which has excess material on it) for the best surface alignment. You will only be able to estimate the exact position since the tip lens will not full slip into position, but you can come quite close.

Transfer these trim lines onto the lens and trim it using a rotary tool with a small circular cutter. Hold it firmly so as not to allow excessive vibration which could generate a crack.

4. Next trim the tip to your marking line. Any small adjustments can be made in the tip much easier than in the lens. Fit the lens into a flush butt-joint alignment.
5. Before you go much further, cover the lens (inside and outside) with protective tape. Use plastic packing tape since you'll need a "release" film on the inside.
6. Place the lens in position. It can be secured with duct tape and small mixing stick pcs if required to hold a close, flush alignment with the exterior wing tip surface.
7. Next add a 3 BID tape around the inside perimeter. This tape should contact about 3/4" onto the tip and 1" over the lens to form a joggle lip. Allow to cure.
8. After cure, trim the lip to a uniform width. The joggle should be wide enough to allow a 3 BID closeout (see step 10 below) and still leave enough room to attach 4 to 6 K1000-06 anchor nuts. A 3/4" lip is sufficient. In this way, the anchor nuts will not show inside the finished lens/light assembly.
9. Drill the lens for the machine screw attachments and carefully countersink them.
 NOTE: Use only two (2) screws top and two (2) bottom to anchor the lens. Place these screws in areas which are relatively flat. Position the light unit to note its relative position before drilling for these screws since it is possible to locate a screw in a position which could be in conflict with the light body.

Next a light housing will be made. There are two methods for this, method one will ultimately require a separate inspection hole for the strobe light, the second method will result in a simplified through-hole for the strobe light but will also require that you reach your hand through the fwd hole where the clear lens is installed. If your hand will fit through o.k., it is perhaps best to use the second strobe light installation method.



Wing tip lens

Trim Orientation

Figure 9-26

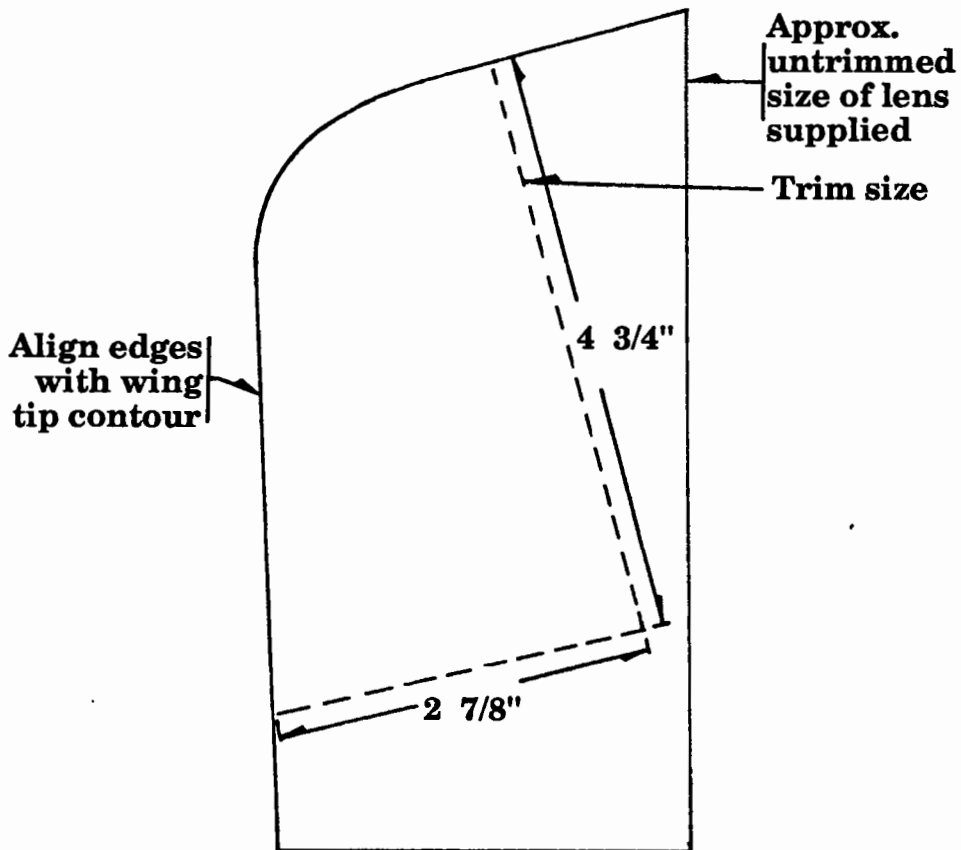

Method 1 - Requires a separate inspection panel for strobe:

10. The colored position lights are designed for an inside corner mount. They have three attachment holes suitable for flat head screw attachment. To box out the lens area, simply lay stiff cardboard or equiv. with plastic release tape tightly against the outside edge of the joggles where the lens fits over. Now from the inside of the tip, lay 3 BID over these plastic covered surfaces and attach onto the inner side of the wing tip.

NOTE: Use care to achieve a nice tight 90° corner which is required for a clean installation of the Whelen light unit. Allow to cure. Remove the plastic coated cardboard and you will have a custom installed closeout on two sides. Use micro to clean up the edges, etc.

- Next fit the Whelen position light unit. It will fit into the corner and attach with three flat head machine screws. You'll need to cut a 1-3/8" diameter hole to insert the base of the light unit through the 3 BID closeout. Attach with machine screws and K1000-06 anchor nuts.

Wing tip position lights

(cross sectional view)

Figure 9-27

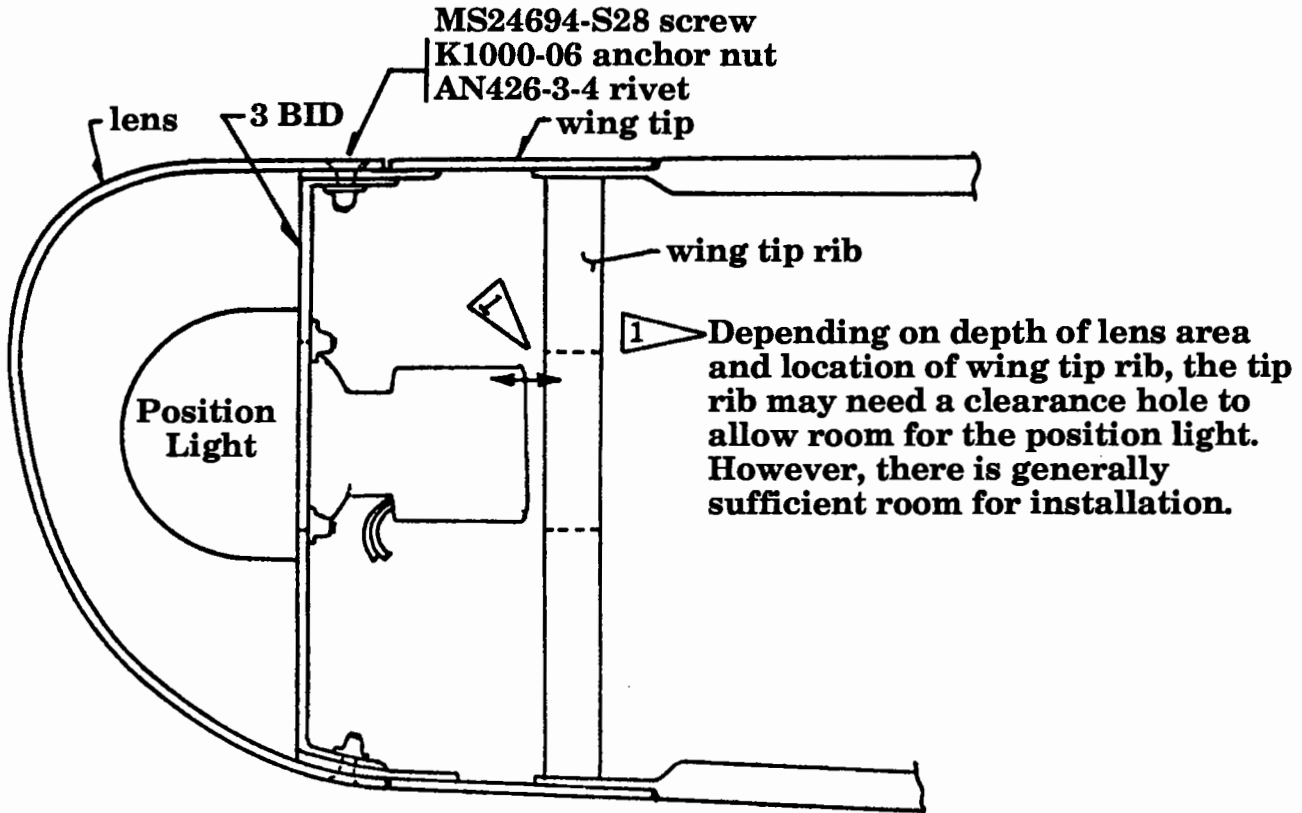

Method 1 - Strobe light installation

Use the Whelen A-625 strobe unit

- Remove the two screws and retainer ring and the lens from the strobe. Be very careful in handling the strobe unit since the tube assembly is delicate and expensive.

13. Per figure 9-28, use a rotary type tool and 1/8" ball end cutter to cut an oval through the tip. The lens can be used as a final sand to fit guide. Note that the lens should be mounted low enough to NOT be visible from the cockpit. Being able to see the strobe flash from the cockpit is blinding and totally unacceptable.
14. When the strobe lens fits properly through the tip from the inside, align and transfer the two attach screw holes. Run these attach screws through the tip to attach the unit.
15. You will now need a means to access this strobe unit for removal after the tip is bonded into position. To accomplish this, cut an inspection panel around the cutout for the strobe lens. Make it large enough to allow room to attach two machine screws, one in front and one in back.
16. Cover the back of the piece with plastic tape and insert it back into position (leave the strobe off). Use duct tape to hold it in flush alignment.
17. Now add a 3 BID tape around the inside to form a mounting flange. When cured, trim and attach the two mounting anchor nuts.

Wing tip strobe light

Cross sectional view

Figure 9-28

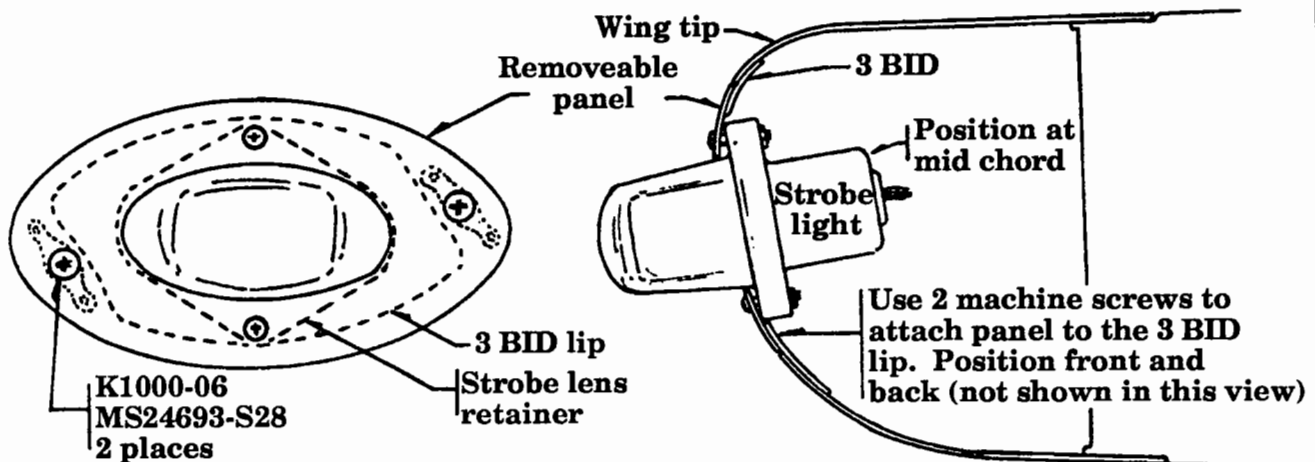

Method 2 - Requires only a through-hole for strobe

This method of closing out the clear lens position light area basically leaves the back panel removable thus allowing access into the wing tip so that the strobe can be serviced through the fwd position light hole.

17. Build the chordwise closeout panel in the fwd wing tip area as shown on figure 9-27. Leave the rear (spanwise) panel off.

18. Next trim and fit a removable panel to close out the aft spanwise area. Use .025" aluminum or similar. See figure 9-29.
19. This panel can simply be siliconed into position under the position light or it can be made with a flange large enough to allow the two rear screw mounts of the position light to pass through it thus securing it in position.

Wing tip light installation
Figure 9-29

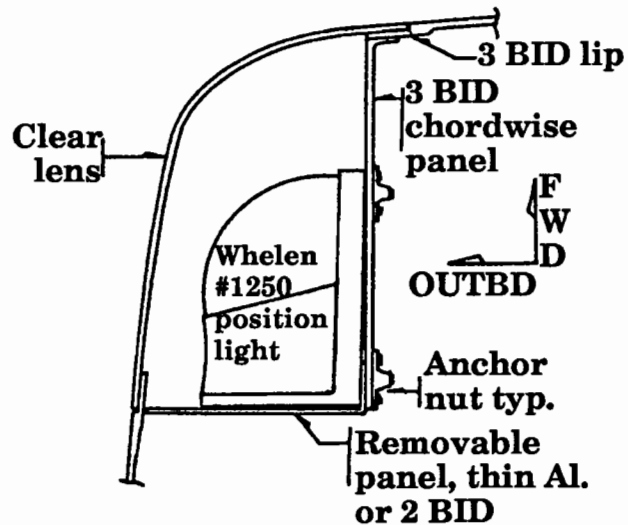

Method 2 - Strobe light installation

Use Whelen A-625 strobe unit.

20. As with Method 1, position and cut the access hole for the strobe lens (only) to stick through the tip, see figure 9-27 for basic reference.
21. Next, align and transfer the two attach screw holes and simply use these to attach the strobe, similarly as shown in figure 9-27 except the strobe will be serviced (removed) by reaching in through the fwd clear lens hole. This method eliminates the added complexity of the inspection panel for the strobe unit and is therefore highly recommended as a preferred installation process.

T. Tail light installation

This is a single tail light mounted into the rudder. There are two fairings which must be bonded to the rudder in order to fair and attach the position light unit.

1. Locate a position on the rudder approximately in line with the elevators. This is a good location for the light. Position the two fairings on the side of the rudder and mark their location.
2. Within the above fairing area at the rudder T.E. make a clearance cut with a rotary tool to allow the light housing to nest into the rudder. Cut only as much as is required for a fit.
3. Bond the fairings into position with either epoxy/flox or structural adhesive. Add 1 BID over the seam and fair it into the rudder with a small amount of micro. Also lay 1 BID across the aft face where the light unit will attach.
4. Drill a clearance hole through the aft face to allow the light unit to insert flush against that face.
5. Drill a through hole for the wires through the rudder L.E. and straight through the spar. This hole should be as close to centerline as possible. You'll have to drill around the lead counterweights that are on the rudder L.E. Use a long 3/16" drill bit. Drill a similar hole through the vertical spar web a couple of inches lower than where the hole is located on the rudder.

Use a long piece of stiff wire to string the two 18 gauge wires for the light.

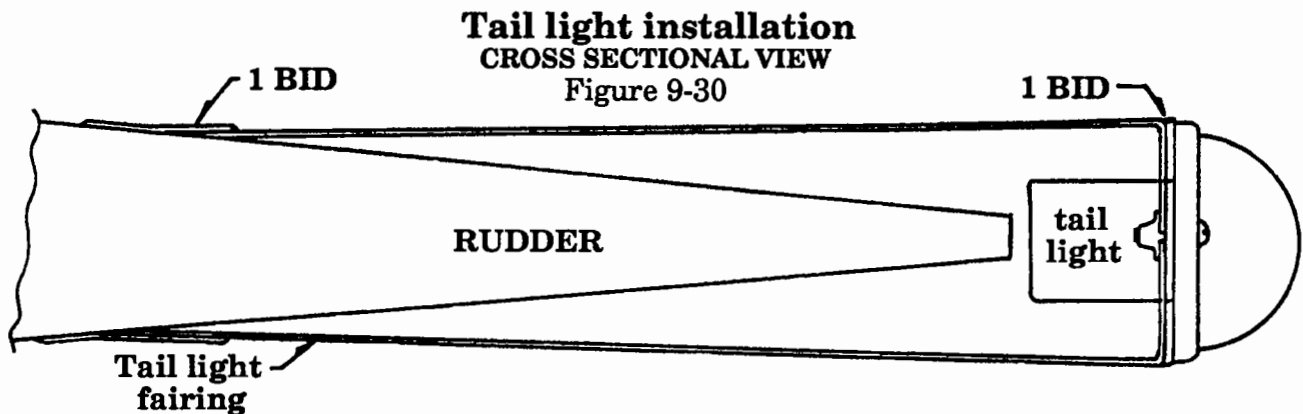

U. Wiring the lighting system

The Whelen lighting system uses the A413A, HDA, DF power supply for the strobe lights. This is a fairly large rectangular unit. It can be mounted vertically against the fwd face of the center main spar or in the baggage compartment behind the seat.

It requires shielded wires due to the high voltage traveling through the wires when firing the strobe lights. It should be carefully mounted so as to keep it well isolated from any possible fuel, oil, hydraulic fluid, etc. that might leak from line fittings.

The lighting wire system will be discussed in the electrical section of the plans. All wires can be run through the PVC tubing which was inserted into the fwd "D" section.

