

OLD WORLD LYRE KIT

MUSICMAKER'S KITS, INC
PO Box 2117
Stillwater, MN 55082

651-439-9120
harpkit.com



WOOD PARTS:

- A. Spruce Soundboard (Front)
- B. Walnut Ply Back
- C. Tail Piece
- D. Arched Cap
- E. Bridge
- F. Cross Piece
- G. Left Arm
- H. Right Arm
- I. Saddle
- K. Inner Brace (Not Shown)

HARDWARE:

- J. Musicmaker Medallion
- L. Tuning Wrench
- M. 10 Zither Pins
- N. 10 Strings
 - End Pin
 - Tail Gut (9" steel cable)
 - 2 Aluminum Crimps
 - Drill Bit: 3/8"
 - 6 Plastic Beads for Nylon Strings
 - 12 Tiny Washers for Steel Strings
- Assembly Instructions

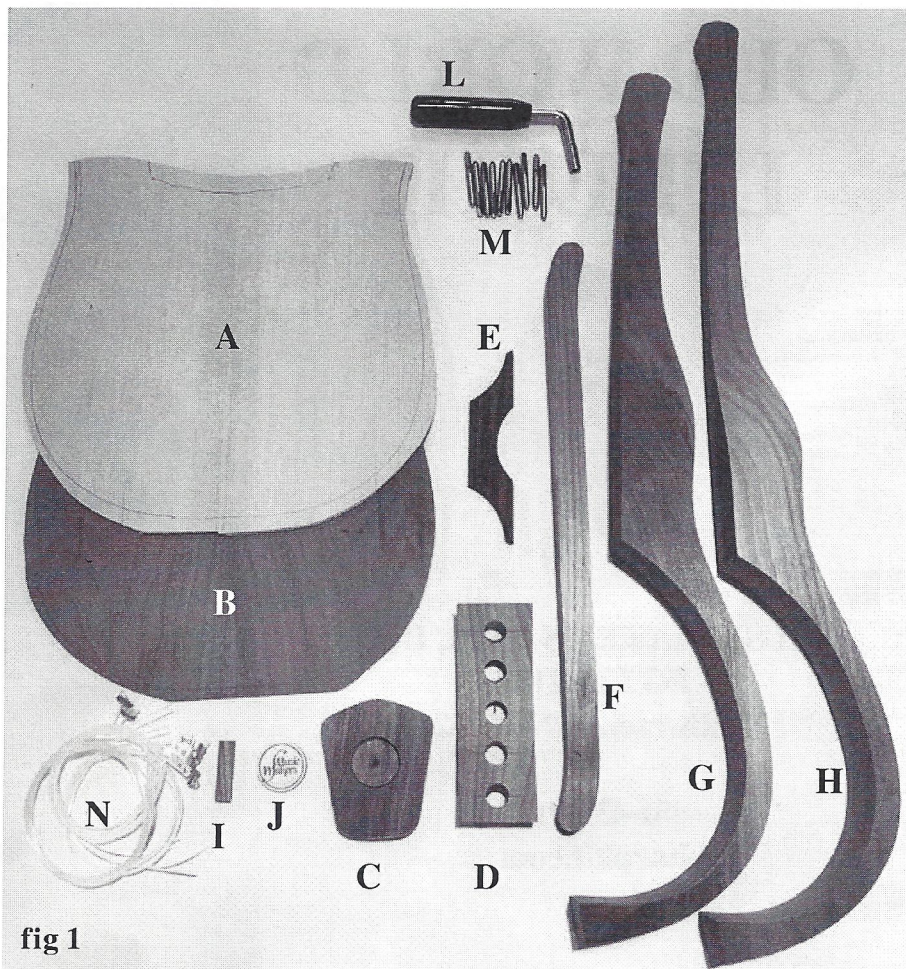

A NOTE ABOUT GLUE

We recommend assembling this kit with standard woodworker's glue (such as Elmer's Carpenters Glue or Titebond Wood Glue). Don't use Hotmelt glue, Superglue, 5-minute Epoxy, or plain white School Glue for assembling the major wood parts -- those adhesives are not strong enough for a high-tension instrument. There is no need to look for any special instrument-maker's adhesive.

Every time you use wood glue on this project, it is wise to have a damp rag handy for cleaning up afterwards. It is always best to scrub away any excess glue that squeezes out of the joints before it dries, especially on the outside of the instrument. Keep your hands and workbench as clean as possible too. Glue smudges will show up vividly on the finished instrument.

ASSEMBLY INSTRUCTIONS

CAUTION: PLEASE DO NOT OPEN THE SEALED PLASTIC BAG CONTAINING THE FRONT AND BACK PANELS UNTIL YOU REACH STEP #4. The light colored soundboard (front) is made of solid Sitka Spruce and needs to be kept very dry until you glue it to the frame.

____ 1. Check over your kit parts to make sure you have everything (see fig. 1 above). Contact us right away if you are missing parts so we can rectify the problem without causing too much delay for you. We also recommend checking off each step in the directions as you finish it. In fact, go right ahead and check off this step now -- feels good doesn't it? Hey -- you're off to a great start already!

____ 2. Gather the four main frame parts and lay them out on a flat work table to see how they fit. The longest arm should be on the right side, and the cross-piece should fit between the two arms with the precut half-lap joints, as shown on the next page. Use **NO GLUE** yet. Just test the parts dry first to see if you need to make any adjustments to the joints.

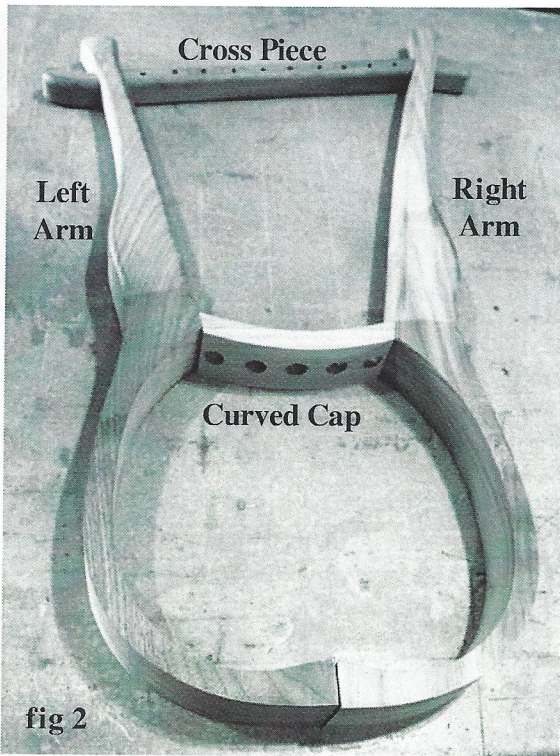

3. Once you are satisfied with how the parts fit, you can begin gluing them together. You'll need two small clamps and some masking tape.

Start by squirting glue in the lap joints where the cross piece joins the two arms, as shown in fig 3.

Put these joints together with glue and use a clamp to hold the parts firmly.

You should see some glue squeeze out of the joints, so you can use a damp rag to clean up the excess. This will save time later -- it is harder to chip the glue away after it has hardened.

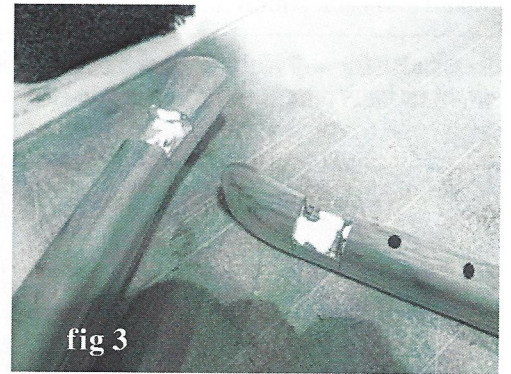

4. Align the tail end of the arms together at the bottom and put glue between them. These curved parts are difficult to clamp (and too fragile to bear much pressure at this point), so we just draw them together with masking tape or strapping tape (fig 4a).

Press one end of the tape down against the wood on one arm and then hold the parts in alignment as you pull the tape across to the other side, as shown. The tape should cross over the glue seam so it will also hold the parts from sliding out of alignment.

Then flip the assembly over and add tape on the back side of this joint and across the bottom, as shown in fig 4b.

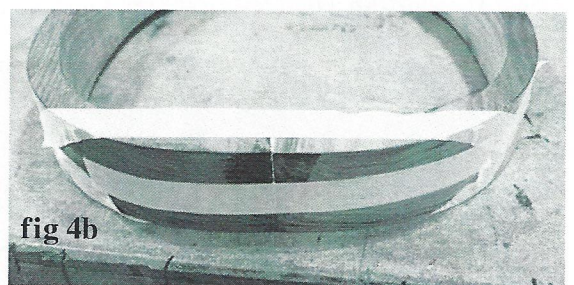
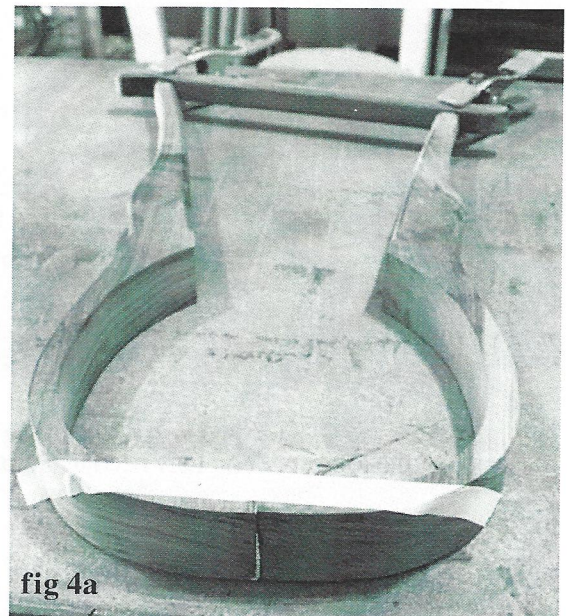

5. Now you can glue the curved cap piece between the two arms, pushing it down until it fits snugly, and using masking tape to pull the arms inward and hold the cap in place (fig 5). Put tape on both sides (front and back) to make sure the cap does not slide out of position.

Be sure to clean up excess glue with your damp rag.

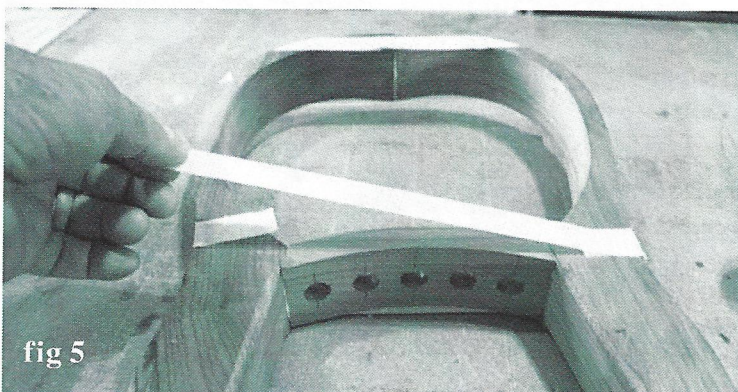

Leave this assembly overnight to dry. It is a bit fragile in this state of assembly, so take care not to drop it on the concrete floor! Adding the front and back panels to the frame will make the whole assembly good and strong.

6. When the glue is dry, remove the tape and check each glue joint for unevenness. Use coarse sandpaper to level the joints (taper the high parts down gradually) to achieve a smooth surface for gluing the soundboard and back panels to the frame (fig 6).

Look also for any blobs of glue that might interfere with the fit of either the front or back panels.

7. Now you are ready to glue the soundboard (front panel) in place. The soundboard is the light colored panel with very straight grain (made of Sitka Spruce). Decide which face you wish to show outward, and place that side facing down on your flat work table.

WARNING: There is a difference between the front and back of the frame. The back is flat all the way up the arms, but the front tapers down from the soundchamber to the cross arm.

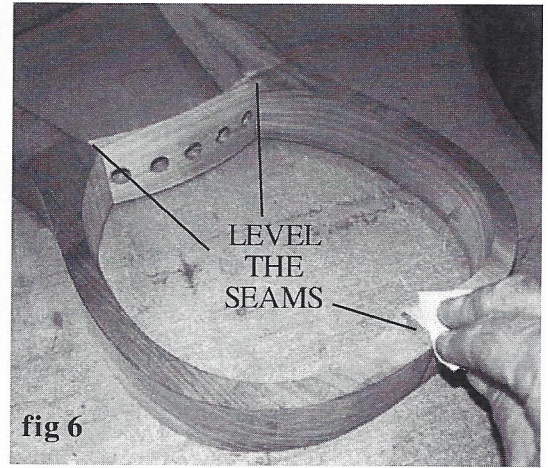

fig 6

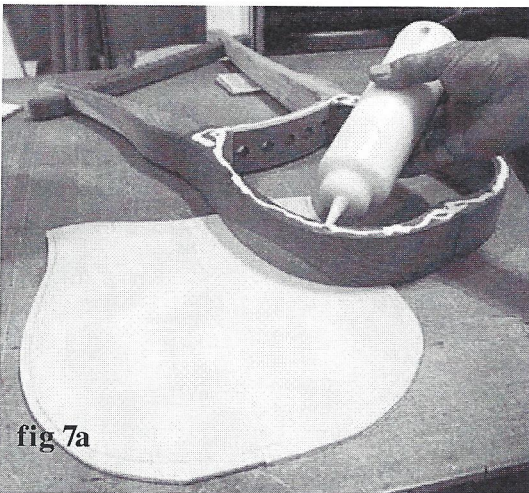

fig 7a

Apply glue to the front of the frame where it will contact the front panel (fig 7a), and then flip the frame over and carefully center it on the soundboard so that some spruce extends beyond the frame all the way around (fig 7b).

Use weights or clamps to hold the frame tightly down against the soundboard until the glue dries.

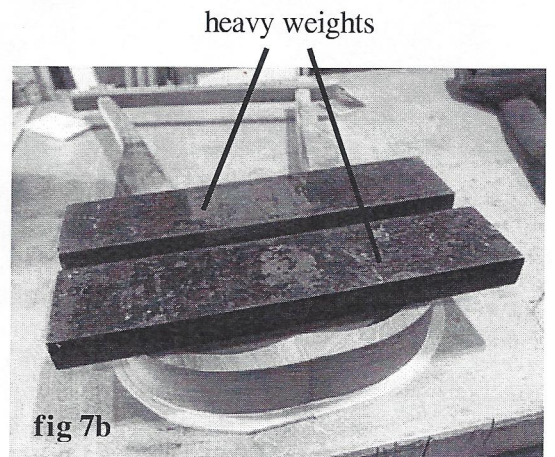

fig 7b

8. When the soundboard is dry, test-fit the inner brace as shown (fig 8a). The brace should be located 4 inches below the inside of the top cap. You may need to shorten it a little to get it to fit. Make sure to also remove any dried glue blobs inside the frame that are in the way of the brace. A sharp chisel should work well for cleaning those off to allow for the brace to sit flat on the inside of the soundboard.

Outline the brace in pencil so you can replace it in the same spot without need for measuring again. Then find a system for clamping the brace inside the box. Fig 8b shows a clamp at each end, which is important, and a scrap of wood being pressed down with a third clamp to put pressure in the middle of the brace. When ready, go ahead and glue the brace.

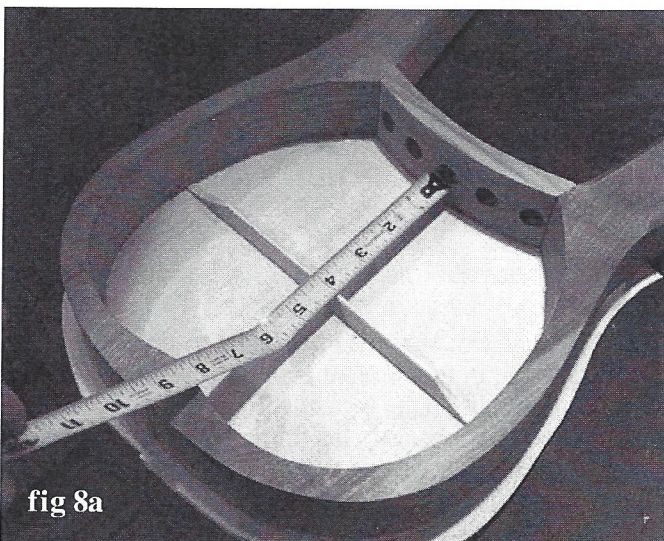

fig 8a

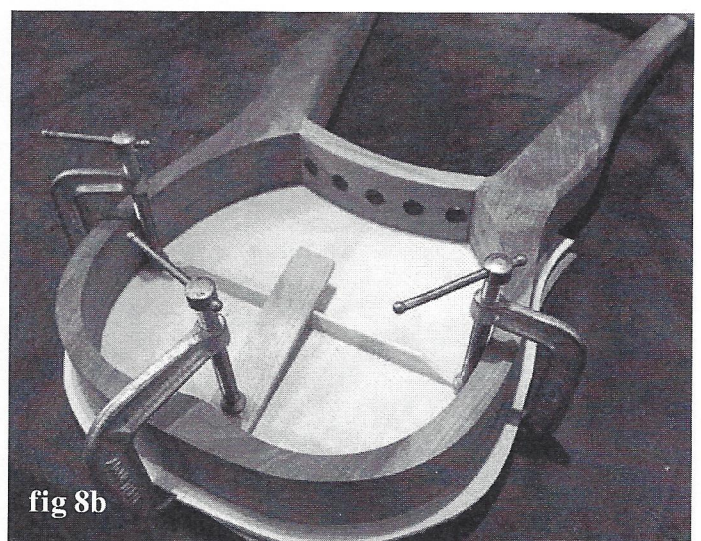
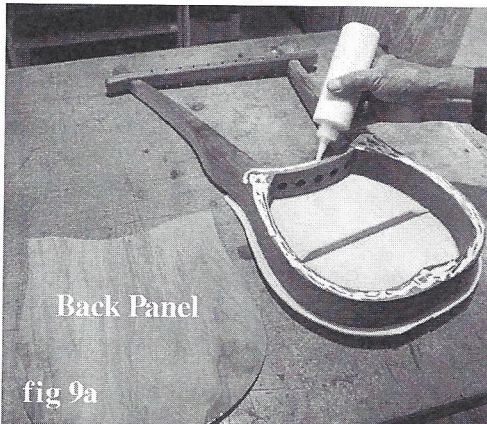

fig 8b

OPTIONAL: If you are thinking of amplifying your lyre, this is the best time to install a pickup, before closing the box. A piezo pickup can be adhered to the inside of the soundboard, with the wire leading to a jack at the bottom of the frame (the jack also acts as the end pin). Once the back is installed, there will be no way to place a pickup inside the instrument, though you could still amplify it by attaching a pickup to the outside.

9. Double-check to make sure the glue joints are level on the back side of the frame too. When satisfied with the smooth surface, apply glue to the frame (fig 9a) and then center the back in place, with the better face showing outward. Use plenty of clamps or weights to hold the back firmly to the frame until the glue dries (fig 9b).



CAUTION: One mistake we've seen novice woodworkers make here is to place the clamping pressure too far inside the perimeter of the box, so the clamps cause the back to be depressed in the middle. Keep the clamps pressing directly above the hardwood frame -- this gives the strongest construction and the best-looking results.

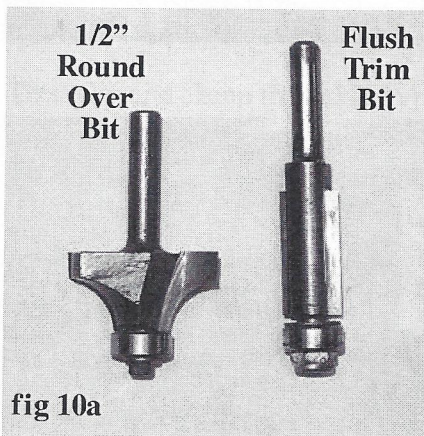
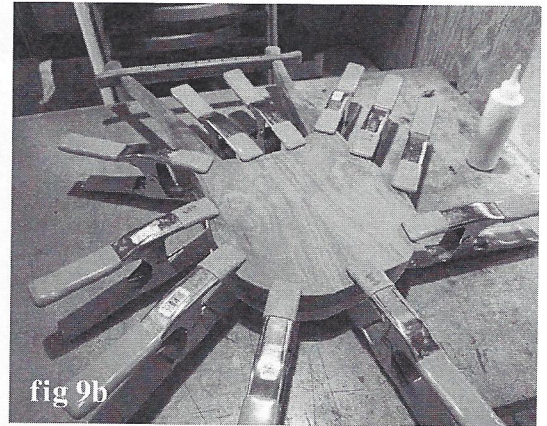

10. When the back is dry, you are ready to trim off the excess overhang on both the front and the back. Can you do this with a coarse sanding block? Well, how much time and energy do you have? How about using a belt sander? Yes, you can sand all but the tight corners between the arms with a belt sander.

By far the best way to trim the soundboard and back flush with the frame, however, is to use a router. If you don't have such a tool in your shop, here is your excuse to buy one! If you enjoy woodworking, you'll find many uses for this great tool.

We use two different router bits, as shown in fig 10a.

HINT: Use the Flush Trim Bit first, moving the router in a clockwise direction around the body of the instrument (fig 10c).

Yes, moving the router around in a clockwise direction violates the normal routing instructions, but here is why we recommend it: This "climb cutting" technique is especially useful when routing thin wood that is easily chipped by the spinning blade. You can do final clean-up by routing the other direction, but if you try to cut off a significant amount of overhanging thin wood, it is best to work the router clockwise around the piece.

When the excess material is trimmed flush, then you can switch to the Round-Over Bit to ease the sharp corners nicely. Move the router clockwise with this bit too. Otherwise you'll end up with lots of little chips in the grain that will need sanding out. Your Lyre should end up looking like ours pictured in fig 10d.

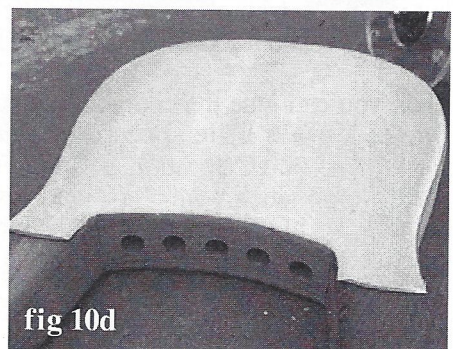
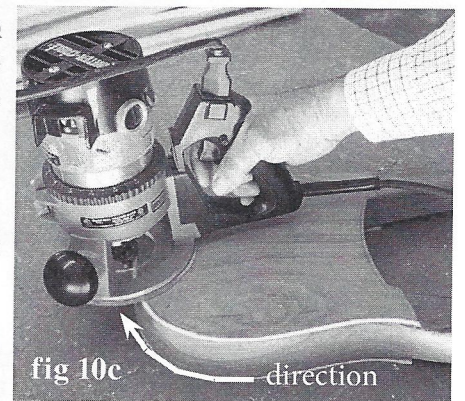
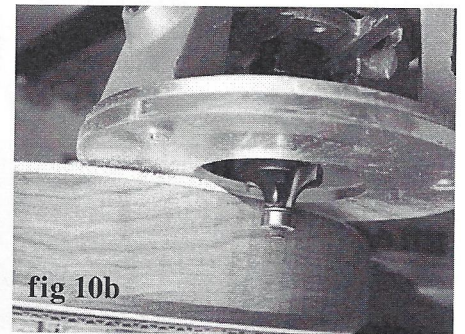

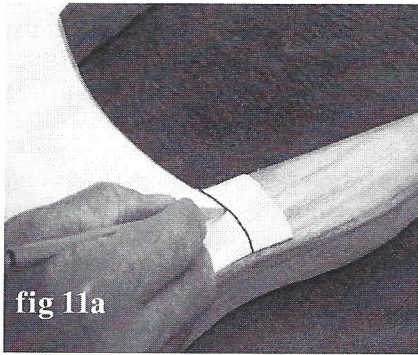

fig 11a

____ 11. We like to trim the excess soundboard and back material that extends a little bit up each arm of the instrument, just to make it look more finished. Use a pencil to draw where you'd like to have these panels end (fig 11a)

Use a sharp chisel to cut away the excess material above the pencil line (Fig 11b). We like to hold the chisel at an angle to make a beveled edge on the wood.

Work the cuts with your chisel until you achieve the profile that you like (Fig 11c).

Then finish up with some medium sandpaper (150 grit) to smooth the contours and clean up any leftover glue residue (Fig 11d).

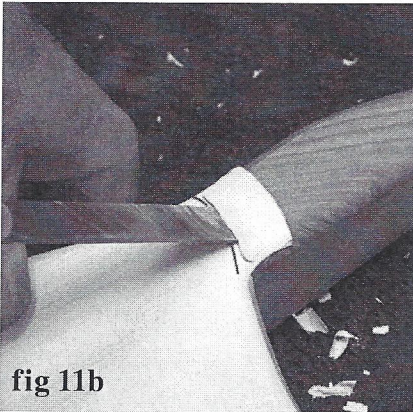

fig 11b

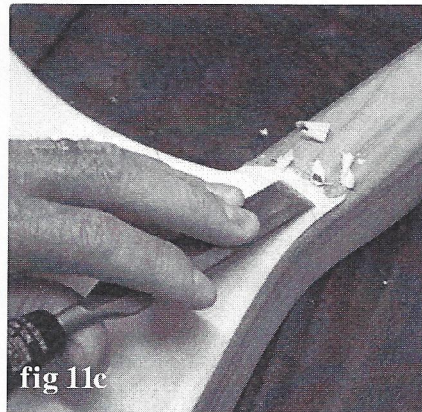

fig 11c

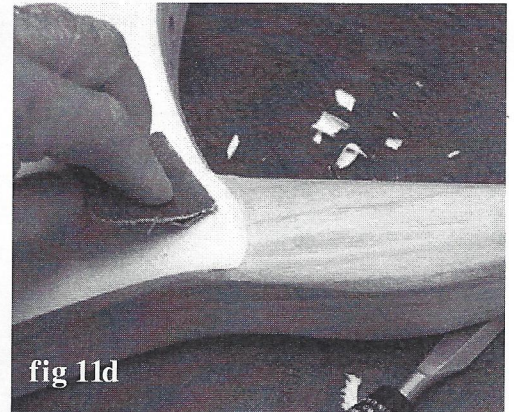

fig 11d

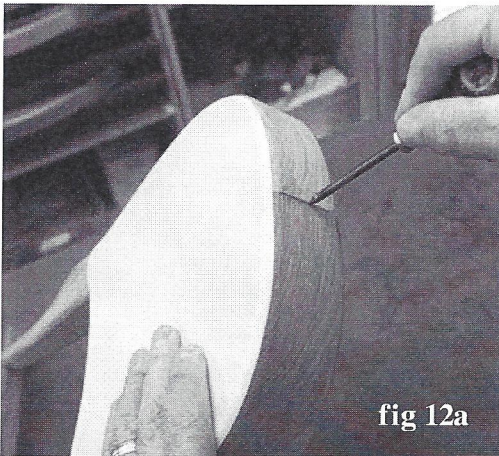

fig 12a

____ 12. If you did not install a pickup jack earlier, you need to drill for the end-pin through the bottom of the frame. Use an awl to punch a mark on the center seam, midway between the front and back panels, as shown at left (fig 12a).

Use the 3/8" drill bit provided to bore the hole for the endpin, all the way through to the inner cavity (fig 12b).

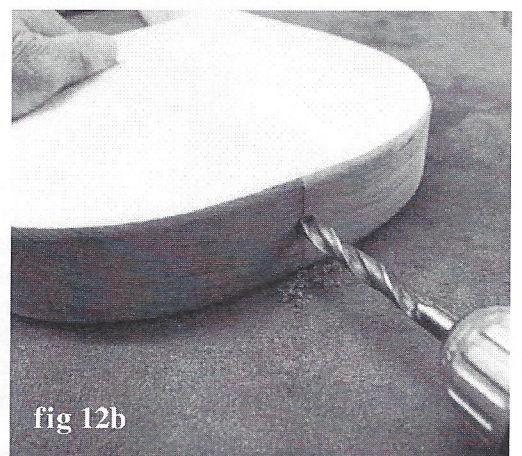
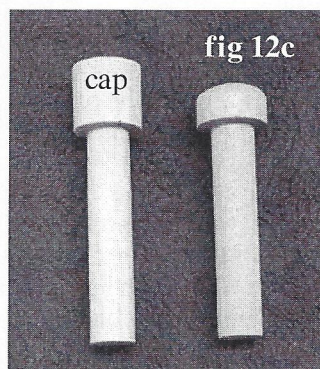

fig 12b

The endpin provided in this kit has a larger cap than is necessary. You can leave it full size, but we like to trim off about half of the cap and round it over so it looks less massive (fig 12c).

Then you can glue the endpin in place, but be sure to leave a little space (1/8") under the cap for the tailgut to hook around (Fig 12d). Squirt some glue into the hole and just a little on the shaft of the pin and push the pin in until you have at least 1/8" space between the cap and the frame.



space under cap

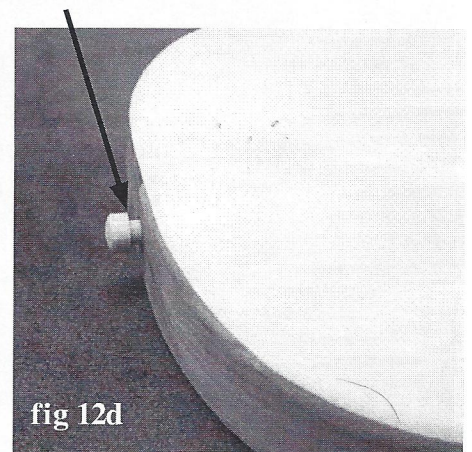
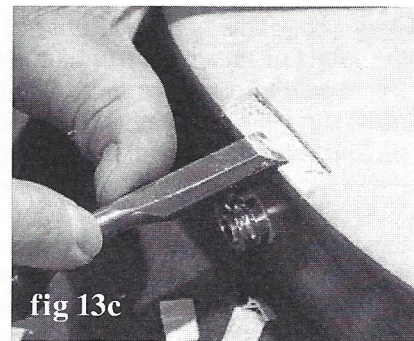
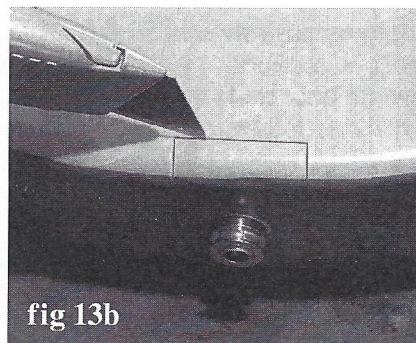
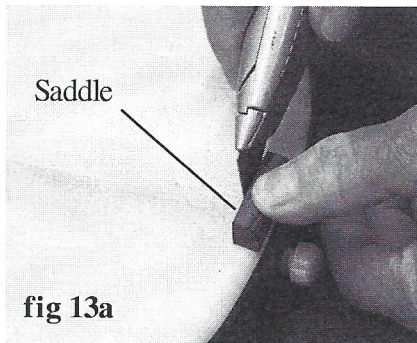
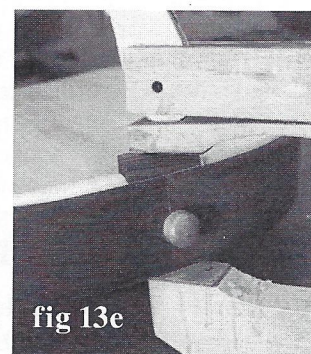
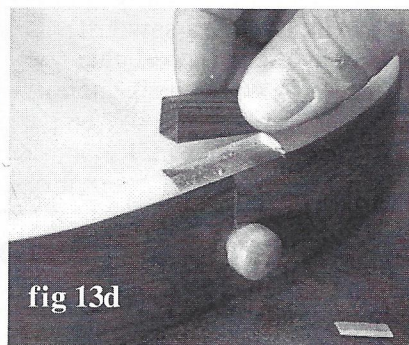

fig 12d



____13. Now you need to inset the little wooden saddle at the tail end of the instrument, just above the endpin. One flat edge will rest on the frame, with the curved corner forming a guide for the tailgut that will hold the tail piece to the end pin. See cover photo to clarify how this will look when done.

Begin by holding the saddle carefully centered above the end pin, and use a razor knife to outline its position in the spruce soundboard (fig 13a). Set the saddle aside while you deepen those outline cuts with the razor knife (fig 13b).



Use a sharp chisel to chip out the spruce within the outline (fig 13c). You will probably need to switch back and forth between outlining and chipping to get down to the walnut frame.

Then glue and clamp the saddle in place, as shown below (figs 13d & 13e).

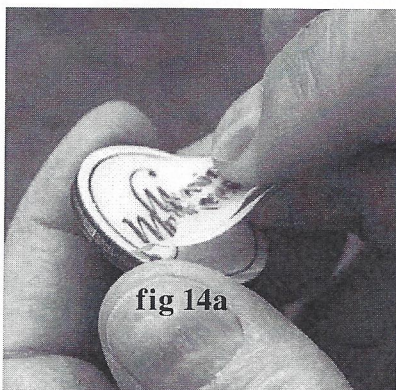

____14. Notice that the Music Makers wood disc has a thin layer of tape on the front. Peel it off as shown at left (fig 14a). Then use 150-180 grit sandpaper to round over the top edge all the way around the disc (fig 14b).

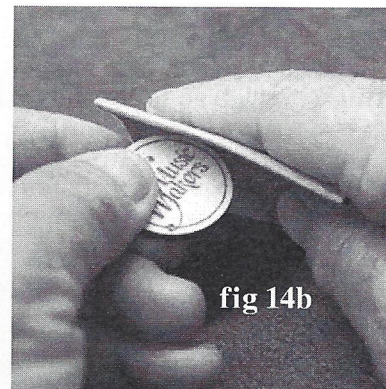

____15. Don't press the disc into place yet! You can either show the engraved face or the back face outward on the tailpiece. If you show the engraved face outward, you need to orient the lettering to read correctly.

TAKE CARE TO ORIENT THE TAIL PIECE WITH THE WIDER END UP, AS ILLUSTRATED!

Without pressing the disc into the hole, place a strip of masking tape on it to connect it to the tailpiece, as shown at left (fig 15a). This will hold the lettering straight.

Flip the disc up out of the way so you can squirt some glue (not too much) into the hole (fig 15b).

Then you can flip the disc back down (tape still holding it straight) and press or tap it into the hole. **NOTE:** The disc is intended to stand a little higher than the surrounding wood. It looks nicer this way than perfectly level.

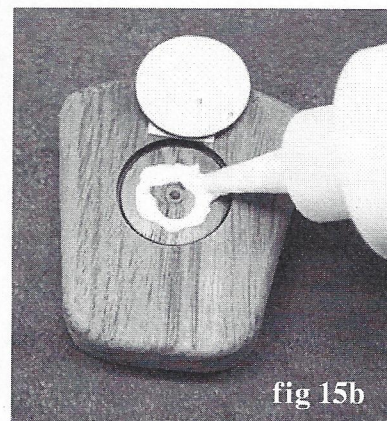
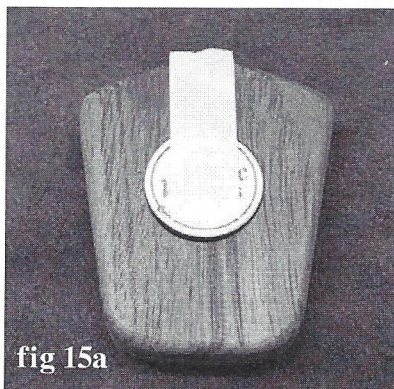

____ 16. This is a good time to check for any gaps in the joints or under the front and back panels. Use wood filler paste to patch them up. There are several brands of good sandable and stainable fillers on the market. We've pictured a couple good ones that we use here (fig 16).

You can purchase these fillers in different colors to match the wood, thus minimizing the noticeability of your repairs. The main thing to look for with fillers is to get one that is marked "sandable and stainable". That way you can darken a little if necessary, to match the wood tone.

Some woodworkers like to mix a little natural sawdust (from sanding the wood) with slightly diluted wood glue to make their own filler paste. This also works well.

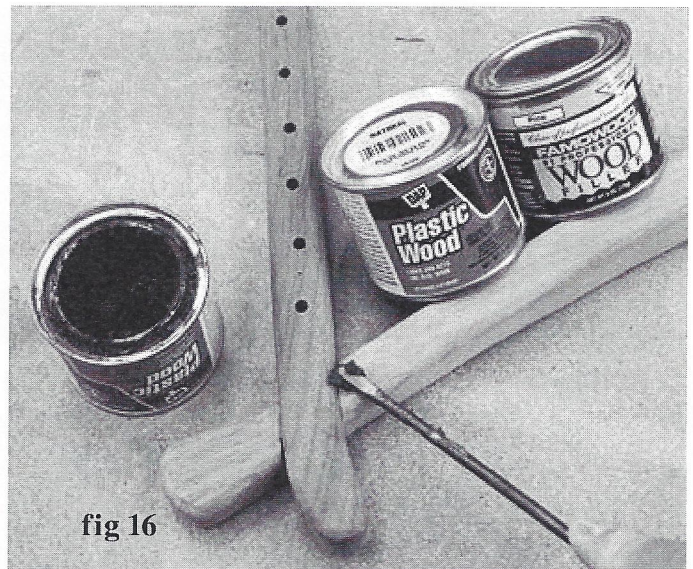

fig 16

OPTIONAL DECORATING IDEAS

If you'd like to make this instrument look more ancient and "hand hewn" (and avoid all the sanding in the next step), you can use carving tools to make shallow gouges all the way around the frame, as shown at right.

This is just as time-consuming as sanding (if not more), but it is a very effective way to decorate the instrument. We recommend a good whittling knife at the very least, and it would be handy to have a couple of gouging (curved) chisels to make the job go faster and easier.

Don't carve the thin front or back panels tough -- that would weaken them. Be very careful to keep your fingers out of harm's way! We went to the first aid box a couple times for small cuts when carving our display model, but if you have good tools and a method for clamping the instrument firmly to your work surface, you'll be well-equipped to do this kind of thing safely. Don't forget to whittle the tailpiece and bridge a little too.

Woodburning on the light colored soundboard is also an effective way of customizing your lyre. That's how we decorated one of the samples shown in the cover photo.

If not interested in this kind of decorative work, then proceed on to step 17 of sanding the instrument smooth.

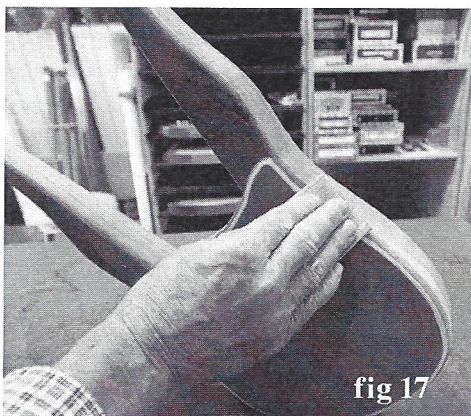
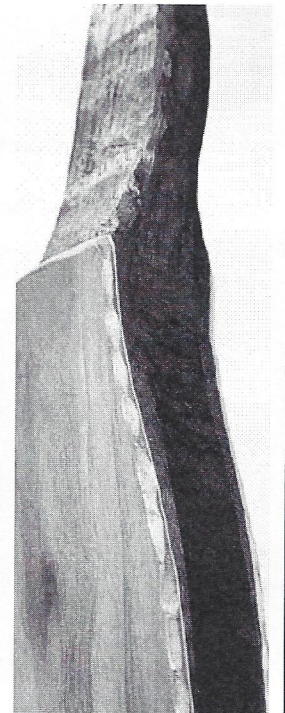
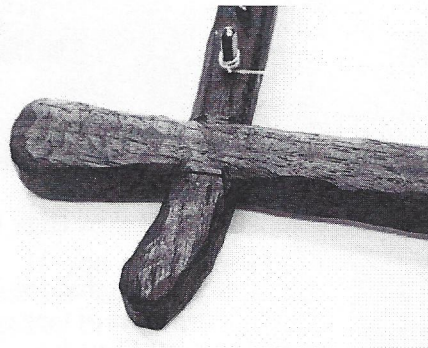

fig 17

____ 17. Now it is time for final sanding. Plan an unhurried time slot for this activity. Find a comfortable chair, put a towel over your lap to catch the dust, and pour a refreshing drink, turn on the TV or radio, and have at it. You may find a few rough spots that require 80-100 grit paper to clean up, but then you'll want to switch to about 180 grit to smooth everything out. Look for machine marks, glue spots, pencil marks, etc., and try to sand with the grain direction wherever possible (fig 17).

Don't forget to sand the bridge and tailpiece too!

People often ask us how our musical kits turn out when built by amateurs. We tell them that the major sign of an amateur job is a lack of attention to sanding. Glue spots, sharp edges, machine marks all point to a hasty job. So take your time and make this something you will be proud to show off!

Now you are ready to apply the finish. Here are some recommendations:

STAIN -- STAINS are coloring agents and should only be used if you dislike the natural color of the wood. We generally discourage people from trying to stain this project because the natural wood grain is so beautiful with a simple clear finish. It is difficult to mask off the soundboard, for instance, and just stain the sides and back of the body because the stain tends to "bleed" under the masking tape. If you are a novice at finishing, or facing a deadline for completion, we especially recommend avoiding stain.

OIL -- An oil finish (such as Watco Danish Oil) will give your wood a low luster appearance, bringing out the natural color of the grain, but it tends to soak into the wood and appear dry and "thirsty" after awhile. The principal advantage of an oil finish is that it can be applied and wiped dry immediately, allowing you to proceed to installing hardware (and strings) right away. The disadvantage of oil is that it usually does not give much surface protection or sheen, unless you know how to polish out many coats of gun stock oil.

POLYURETHANE -- Any polyurethane will work fine on this project, but we like the solvent-based ones better than water-borne versions. Our all-time favorite is wipe-on Gel Topcoat polyurethane (shown at right) that comes with our Instrument Finishing Kit. It is the product featured in our Musicians catalog, and we provide application instructions for it here in the next step. The advantages of this finish are its simple application (no drips or runs), its excellent durability, and the deep, soft luster it gives to the wood surface.

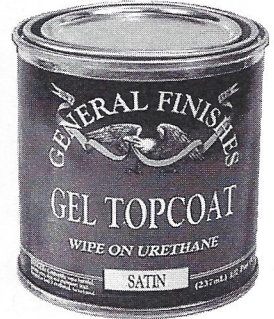

LACQUER -- Many professional instrument makers still use nitro-cellulose lacquer for their finish. The most readily available lacquer is called Deft Clear Wood Finish. If you choose this product, it is best to purchase a can of liquid to brush on as a sealer coat first, and then use an aerosol can of the same product to spray the final coats. The advantage of this finish is its quick drying time, but the disadvantage is the strong odor and toxic lacquer fumes. **CAUTION:** Lacquer finish may smear some painted decorations or blister some types of decorative decals. If you plan to add paints or decals to your instrument, it would be better to finish with polyurethane instead of lacquer.

So choose your weapon and proceed with finishing all the wood parts. Plan on applying at least three coats of finish. If you don't use our Gel Topcoat, be sure to follow the directions on the can.

18. We use a cheap foam applicator to apply the first coat of gel (fig 18a) because the first coat will just soak into the wood anyway. The goal is to get finish into all the nooks and crannies so everything gets covered. No need to worry about brush strokes for this because, if you read below, you'll see that all excess finish must be wiped off anyway.

DO NOT APPLY A THICK COAT: YOU'LL JUST WASTE PRODUCT!

NOTE: The temptation is to create a deep "pool" of finish on the wood right away. Please resist this urge, as it will produce bad results and take forever to dry. The best finishes are applied in very thin coats.

CAUTION: be careful about forcing varnish into the tuning pin holes in the cross arm at the top of the instrument. Squeeze out the excess varnish from your foam applicator before going over those open holes.

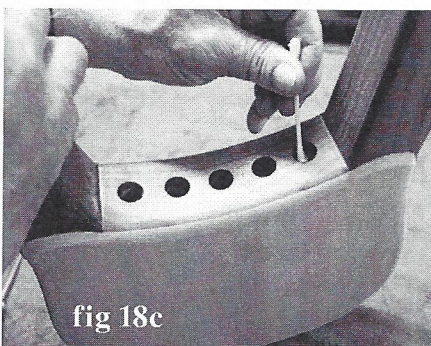

On the other hand, however, you might get a Q-tip to swab some finish inside the five larger soundholes of the cap piece that forms the top of the body (fig 18c). It looks nice to darken the edges of those holes with at least one coat of varnish.

Once the wood has been fully covered with varnish, use a clean cloth or paper towel to wipe off the excess liquid (fig 18b). This will help the finish dry more quickly, though it will still take overnight before you can proceed with a second coat.

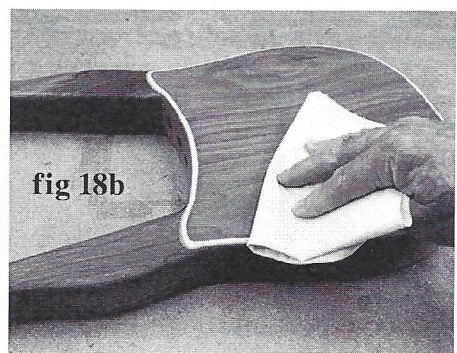
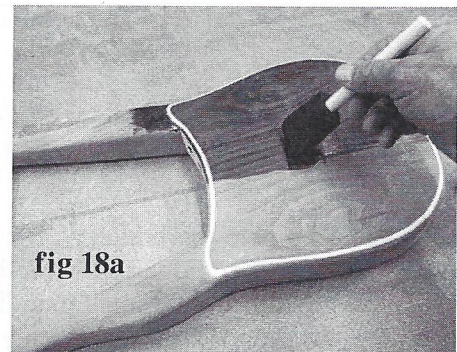

____19. Test to make sure the finish is dry. It may seem dry enough to the touch, but if you wipe your fingers across the surface and feel any “drag” from the finish, then it is not quite fully dry. Adding another coat on top of a partially dry coat will just extend the amount of time it takes for both coats to dry.

When dry, use 600 grit sandpaper to smooth out the surface (fig 19a). Wipe it clean before applying another coat.

Use a clean rag (we like cotton t-shirt material) to wipe on a thin second coat. Again, you just want to wet the surface and then wipe off any excess varnish. These wiped-on applications will dry more quickly than the first coat because the wood pores are already sealed. If you are working in a warm dry environment, it might be ready for fine sanding again in 3-4 hours. Test it by touch, as mentioned earlier.

THAT’S IT! This is all there is to our simple finishing system. You just repeat step 19 until you like the results. We recommend a minimum of 3 coats of finish to give a good protective seal on the instrument. After that, it keeps getting more beautiful.

NOTE: If you wish to add other decorations to the instrument (decals, paints, etc.), it is smart to do that work between layers of gel finish. The urethane will seal the decorations permanently to the instrument.

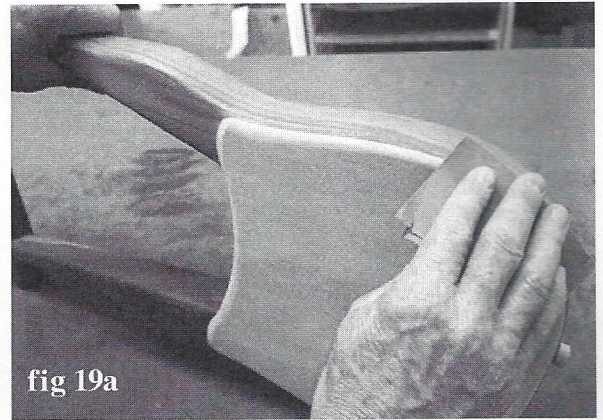

fig 19a

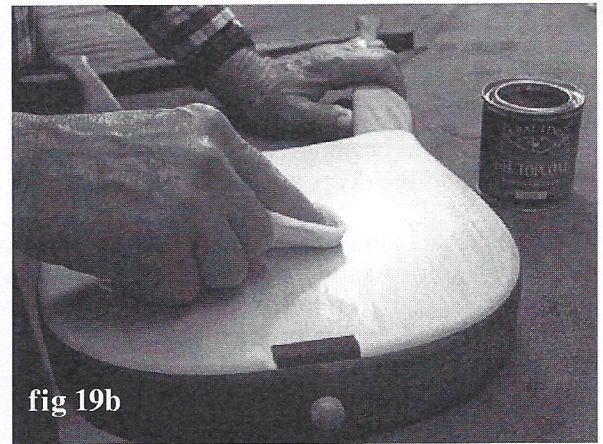

fig 19b

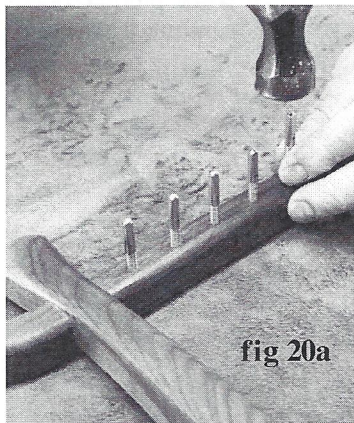

fig 20a

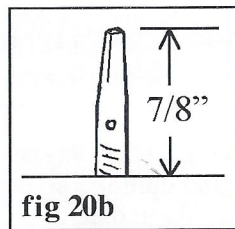
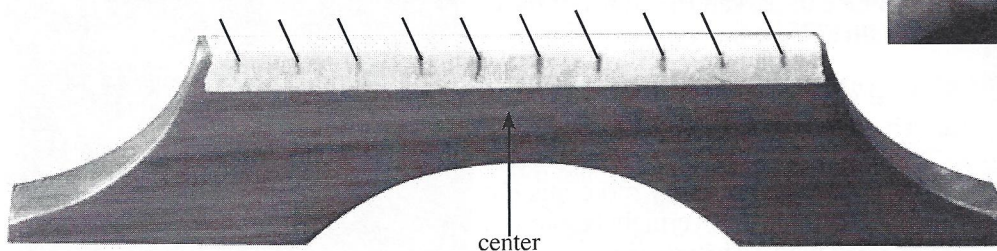

fig 20b

____20. Use a hammer to install the ten tuning pins into the cross bar (fig 20a). Be sure to put the threaded end into the hole. The square end aims up to fit the tuning key. Pound the pins down to about 7/8” height (fig 20b).

____21. Prepare the bridge as follows: Put masking tape over the top edge of the bridge and mark the positions for ten strings as shown in fig 21a. Use a small triangle file to mark the notch positions into the wood (fig 21b). Then you can remove the tape. The notches should be angled to the left a little because of how the bridge will be oriented on the front -- see step #24.

8mm spaces between lines, angled to the left



center

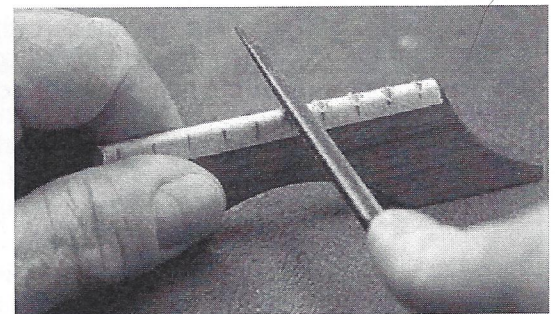

NOTE: The tail gut for this instrument is made of steel cable because anything weaker will break from the string tension! We have secured one end of the cable for you, so please take care to secure the other end carefully.

22. Thread the plain end of the tailgut through one hole in the tail piece from the inside, and then back through the other hole to the inside, as shown in fig 22a. Find the extra aluminum crimp and push the cable through one side of it and back down into the other side of the crimp, so the end is hidden in the crimp (fig 22b). Pull the crimp to tighten the small loop to about 1/4" size (fig 22c). Then use a hammer to pound the crimp firmly against a cement floor or steel anvil to flatten it so the wire cannot be pulled back out. Pinching it hard in a metal vise also works well.

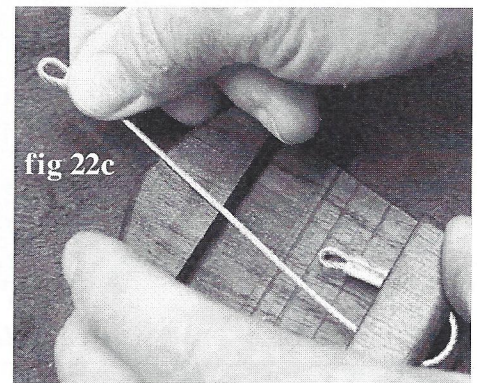
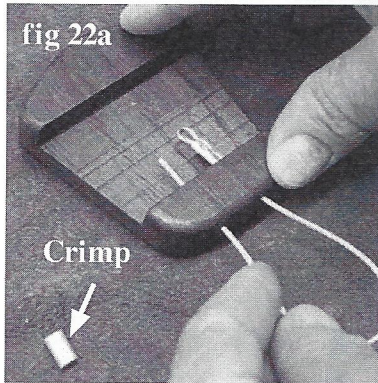

If your tail piece looks like the one shown in fig 22e, with both crimps crimped, you are ready to string up this lyre! If you have wire strings in your kit, start below. If you have nylon strings, skip to the next page.



WIRE STRING INSTALLATION

It is easiest to insert all the strings into the tailpiece first. Begin with string #10 (Middle C), which is the thickest string. The steel strings are individual ball-end strings which need a tiny washer added onto the end before threading through the tail piece. Turn the tailpiece upside down, as shown in Fig 22g, and thread the thickest string through the first hole at left side of the tail piece. **NOTE:** the wound strings are on the left when the tailpiece is upside down, but will be reversed when you turn the tailpiece right-side-up. Basically, the thickest string goes in first, and the thinnest one last (see string chart below), so just continue with all of them in order (bottom to top of chart), with a tiny washer on each.

Wire Strings

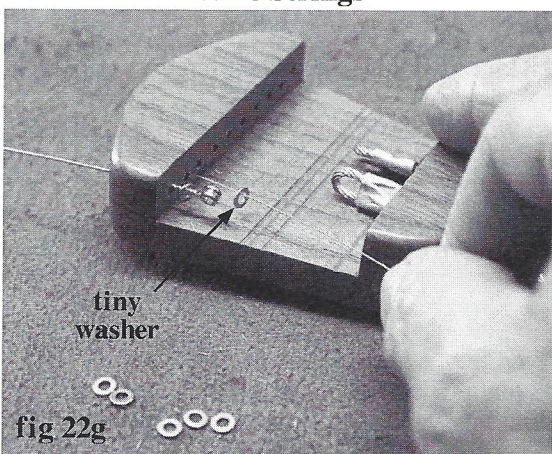

NOTE: The tiny washer prevents the ball end from digging into the wood and getting "buried" in the tailpiece.

STRING CHART FOR WIRE STRINGS

String Note	Gauge	Code
1 High E 5	.010	BALL010
2 D5	.010	BALL010
3 C5	.012	BALL012
4 B4	.012	BALL012
5 A4	.014	BALL014
6 G4	.014	BALL014
7 F4	.016	BALL016
8 E4	.016	BALL016
9 D4	.018	BALL018
10 Mid C4	.020	BALL020

NYLON STRING INSTALLATION

It is easiest to insert all the strings into the tailpiece first. The Nylon strings are long enough to loop through the bridge and up to two neighboring tuning pins, so each length of nylon will give you two strings on the instrument. Begin with strings #10 (Middle C4) and #9 (D4), which use the thickest string (.050"), on the left side of the tail piece when it is upside-down, as shown in fig 22h.

NYLON STRING CHART			
String	Note	Gauge	Code
1	High E5	.025	NYL025
2	D5	.025	NYL025
3	C5	.032	NYL032
4	B4	.032	NYL032
5	A4	.036	NYL036
6	G4	.036	NYL036
7	F4	.040	NYL040
8	E4	.040	NYL040
9	D4	.050	NYL050
10	Mid C4	.050	NYL050

Install one plastic bead between each pair of strings, as follows:

One length of nylon makes two strings, but don't cut it in half. Thread a bead to the center of the string and poke both ends of the string through the first two holes in the tailpiece. Pull evenly until the bead is tight against the tail piece and you have equal lengths of nylon for each string (fig 22h). Continue with remaining pairs until all the strings are in the tailpiece.

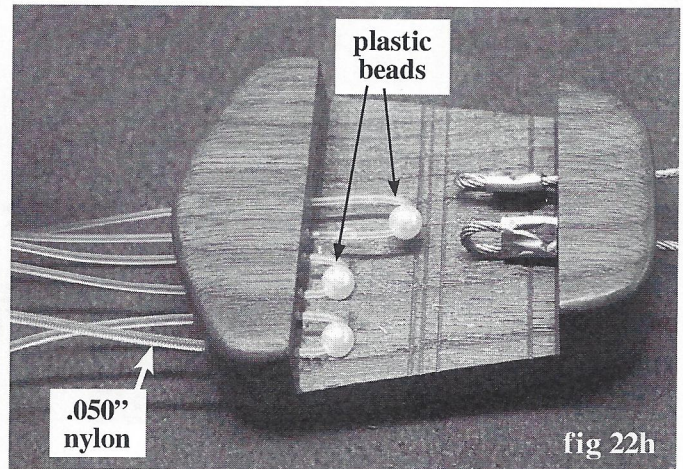

23. Now you can flip the tailpiece right-side-up and hook the steel tailgut around the end pin, as shown in fig 23a. Here's how to begin stringing:

A) Find the two middle strings -- #5 (D4) & #6 (E4) -- and stretch them out past the two middle tuning pins. Cut them about 3 inches beyond the pins, as shown (fig 23b).

B) Poke the end of one string into the proper tuning pin so just a little of it shows on the other side (fig 23c).

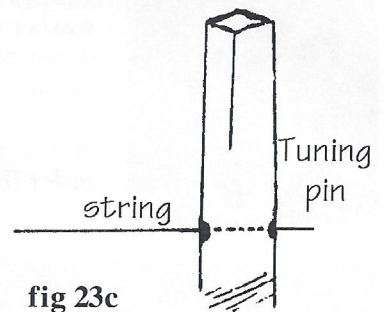
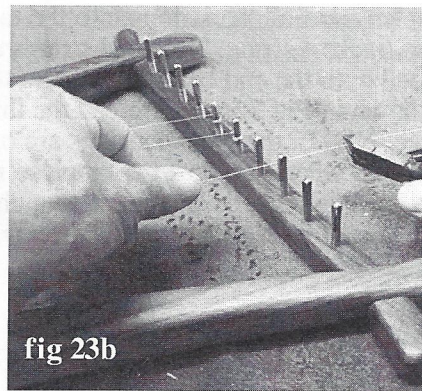
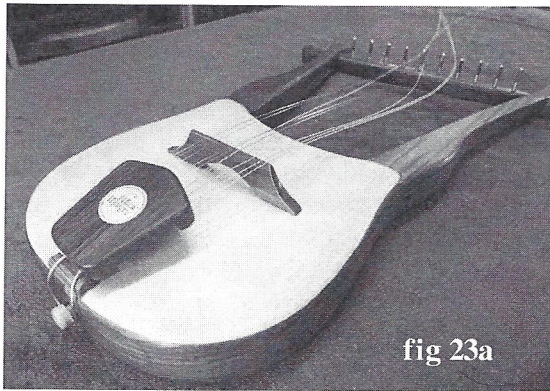

C) Use the tuning key to turn the pin clockwise half a turn, so you can pull it taut without the string coming out (fig 23d).

D) Then continue holding the string taut as you turn the pin clockwise to wind the string nicely on the pin until there is a little tension on it (Fig 23e).

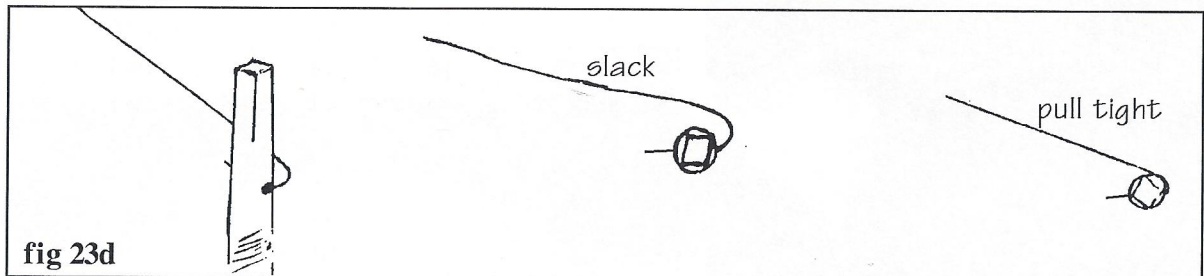

WARNING: Don't tighten the pin so far that you break the string! Just draw the slack out of the string so it makes a clear tone when plucked.

Guide the windings downward on the tuning pin as you turn the key clockwise. It is best to start each string with enough slack to achieve 3-5 wraps around the tuning pin.

It is best to have the string pull from a low position on the pin, as opposed to pulling near the top of the pin (see Fig 23f). This reduces the twisting force on the pins and the top cross piece of the frame.

HINT: Nylon strings are quite slippery, so we like to secure the strings to the tuning pins by crossing the string over itself once while turning the pin. Look closely at fig 23f to see how that is done. It will help the strings stabilize more quickly on your Lyre.

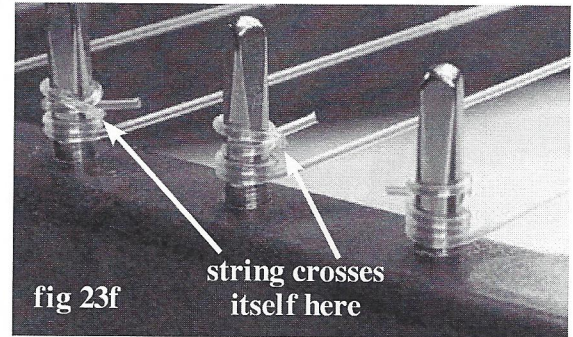
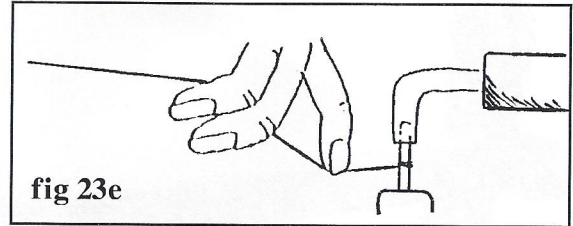

____ 24. Before you get all the strings in place, you'll want to slide the bridge to its optimum location. When we tune the Lyre to the notes shown in the tuning chart, we place the bridge at an angle so the highest string will have a vibrating length of about 13" and the lowest string about 17" (see figs 24a and 24b). Just measure the space between the tuning pin and the top of the bridge at each end.

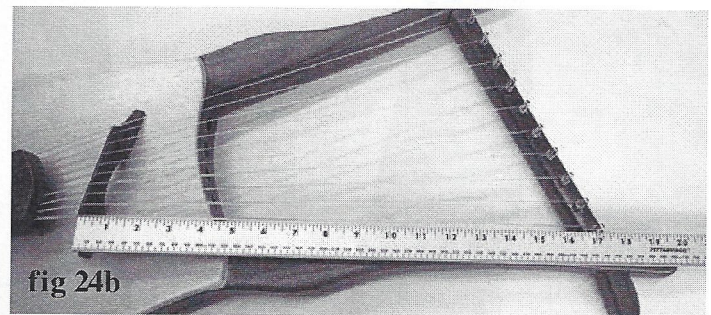
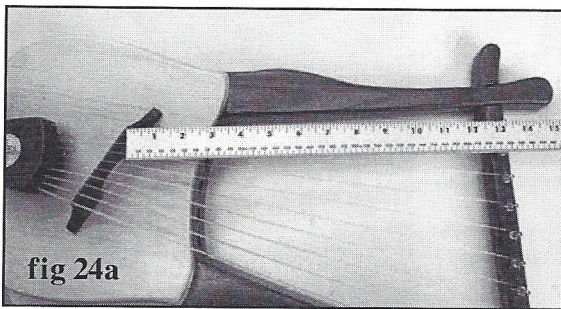

____ 25. Once all the strings are installed, you can begin tightening them up to pitch. This may require several tunings because the strings (especially nylon) are stretching and the instrument is adjusting to the tension.

Tune the strings to the C major scale, beginning on Middle C (longest string) and proceeding up the scale to high E5 (shortest string). If you don't have a piano or keyboard to help with this, go to our on-line tuner at harpkit.com/freetuner.

Don't worry that one half of each nylon string is being used for a different note than the other half. Tune each pair fairly evenly, and when they are close to the correct pitch, you can fine tune them to their respective notes. The tension on each half of the pair will be so similar that there will be no slippage through the tail piece.

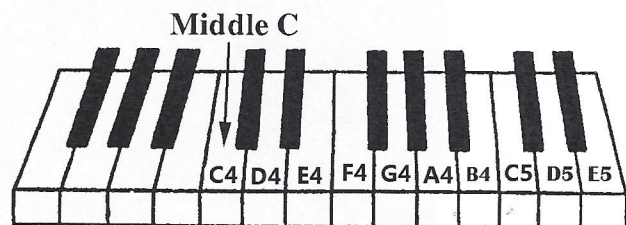

____ 26. If you installed wire strings on this instrument, we recommend clipping the stubs of wire as short as possible next to the tuning pins, just to avoid poking yourself or catching your clothing on those sharp ends of wire.

CONGRATULATIONS! We hope you have enjoyed this unusual project. We are always listening for feedback, good and bad, to help us improve the quality of our kits and the clarity of our assembly instructions, so don't be shy. We hope you have lots of fun with your handmade instrument.



NOTE: We have an excellent instruction book for this size instrument called, "Learn To Play the 10-string Davidic Harp". It has note-reading instruction, fingering technique, practice exercises, and a number of traditional hymns to play.

Contact us or check our web site for price and availability.

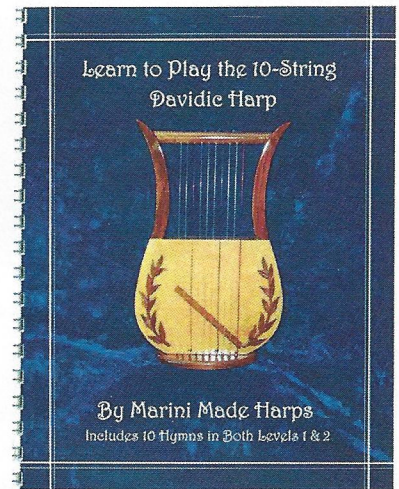

MUSICMAKER'S KITS, INC
PO Box 2117
Stillwater, MN 55082

651-439-9120
harpkit.com